

Not Transferable
Security Classification: Non-Security



बैंक नोट पेपर मिल् इण्डिया प्रा. लिमिटेड
BANK NOTE PAPER MILL INDIA PVT LIMITED
JV of SPMCIL - A Govt. of India Enterprises & BRBNMPL - A Subsidiary of RBI

TENDER ENQUIRY FOR SUPPLY OF KNIFES FOR BALE PRESS AT BNPM PLANT, MYSURU.

This tender document contains 26 Pages

Tender Enquiry No.	BNPM/OTE/445/2024-25
Tender issuing date	27.12.2024
Pre-bid meeting date & time	Not Applicable
Due date & time for bid submission	17.01.2025 till 11:00 hrs.
Mode of bid submission	Online
Type of tender	Open Tender
Tender Processing Fee	Rs. 250/- + Taxes
Details of contact person	Deputy General Manager (SCM) 0821-2401111/181/180

Registered & Corporate Office:
Administrative Building
Gate 1, Paper Mill Compound
Note Mudran Nagar, Mysuru - 570 003
Telephone No. 0821 - 2401 111

e-mail: scm.tender@bnpmindia.com

website: www.bnpmindia.com

List of Contents

Section I	Notice Inviting Tender	Enclosed
Section II	Terms and Conditions	Enclosed
Section III	Technical Specifications	Enclosed
Section IV	Quality Control Requirements	Enclosed
Section V	Declarations	
	Annexure - A	Enclosed
	Annexure -B	Enclosed
	Annexure - C	Enclosed
Section VI	Price Bid format	Enclosed

SECTION I - NOTICE INVITING TENDERS

1. E-tenders are invited from eligible and qualified tenderers for supply of following goods:

Schedule No.	Brief Description of Goods / Services	EMD**	Required Quantity (in No's)
1	Dead (Counter) Knife for Bale press, Drg No :BNPM/FH/323/2024-25, MOC: HSS (M2 Grade)	Rs. 3,000/- (Rupees Three Thousand only)	4
2	Movable centre Knife for Bale press, Drg No :BNPM/FH/324/2024-25, MOC: HSS (M2 Grade)		4
3	Movable Left side Knife for Bale press, Drg No :BNPM/FH/325/2024-25, MOC: HSS (M2 Grade)		2
4	Movable right side Knife for Bale press, Drg No :BNPM/FH/326/2024-25, MOC: HSS (M2 Grade)		2

****For MSE Bidders:** Submission of EMD is exempted for **Micro and small enterprises (MSEs)** as per the Public Procurement Policy for MSEs Order, 2012. MSEs should be registered and also continue to remain registered during the tender validity period with District Industries Centre (DIC) or Khadi and Village Industries Commission (KVIC) or Khadi and Industries Board (KVIB) or Coir Board or National Small Industries Commission (NSIC) or Directorate of Handicrafts and Handlooms or UDYAM Registered or Any other body specified by Ministry of MSME.

For Start-up Bidders: Submission of EMD is exempted for Start-up bidders recognized by DPIIT as per the Office Memorandum No. F/20/2/2014-PPD(Pt.) of Ministry of Finance dated 25.07.2017. Start-ups should be registered with Department for Promotion of Industry and Internal Trade (DPIIT).

Documents:

For **MSE bidders:** Valid NSIC / KVIC / KVIB / DIC / UDYAM Registration certificate.

For **Start-up Bidders:** Valid Certificate of recognition issued by DPIIT.

Bid Security Declaration as per **Annexure-C** is to be submitted by bidders claiming EMD exemption.

For **Non-MSE/Non-Start-up bidders:** EMD is to be submitted.

1. Interested bidders may obtain further information about this requirement from the above office selling the documents. They may also visit our website www.tenderwizard.com/BNP mentioned above for further details.
2. Aspiring Bidders/Contractors who have not registered in e-tendering should register through the website E – Tendering (www.tenderwizard.com/BNP) for participating in the Online Tenders. The registration charges will be Rs. 500/- plus applicable taxes (per year) which needs to be paid through electronic mode only.
3. For details, registration and e-payment, please visit e-tendering website www.tenderwizard.com/BNP or contact **KEONICS help desk @ 080-40482000, 8951906455**.
4. The NIT Form with standard tender documents will be accessible in the e-Tendering website (viz www.tenderwizard.com/BNP).
5. Class III Digital Signature Certificate (DSC) is mandatory to participate in e-Tenders. Participating bidders/Contractors have to make sure that they have the valid DSC. If not, they can procure from any of the firm as approved by CCA.
6. The tenderer shall satisfy BNPMIPL that they are competent and authorized to submit tender and/or to enter into a legally binding contract with the BNPMIPL. To this effect, any person giving a tender shall render documentary evidence that his signature on the tender submitted by him is legally binding upon himself, his firm or company as the case may be.



SECTION I - NOTICE INVITING TENDERS

7. For those tenderers whose technical bids do not satisfy the eligibility criteria, their financial Bids will not be opened.
8. In the event of any of the above mentioned dates being declared as a holiday/ closed day for the purchase organization, the tenders will be sold / received / opened on the next working day at the appointed time.
9. BNPM reserves the right to cancel the tender at any stage without assigning the reasons thereof.
10. The tender documents are not transferable.

Yours faithfully,
For and on behalf of BNPMIPL

--sd--
Assistant General Manager



SECTION II – TERMS AND CONDITIONS OF THE TENDER

1. Tenders are to be uploaded on e-tendering portal www.tenderwizard.com/BNP only in Two part bid system.
2. i) **Part-I – Prequalification Bid & Techno-commercial Bid:** Scanned copy of Technical offer (catalogue/brochure etc.), Certificate of Incorporation/Partnership Deed (as applicable), GST, PAN, Bank details etc., along with all sections & annexures of this tender.
ii) **Part II – Price Bid:**
Price shall be furnished through e-portal only. Price offer submitted in any other format will be liable for rejection.
3. **Payment terms:**
 - a) 100% amount of the invoiced value shall be released within 30 days on receipt and acceptance of goods by the consignee at destination (i.e. BNPM, Mysuru) and on production of all required documents by the supplier.
 - b) Payment will be made only if the supplied consignment meets the specifications & quality criteria mentioned in the Technical Specifications.
4. **Delivery Schedule:** Successful bidder shall complete supply of goods within **19 weeks** from date of placement of purchaser order (Ref scope of supply).
5. **Liquidated Damages:** In case your quotation is accepted and order is placed on you, the supply against the order should be made within the period stipulated in the order. BNPMIPL reserves the right to recover any loss sustained due to delayed delivery by way of penalty. Failure to supply the material within the stipulated period shall entitle BNPM to impose liquidated damages without assigning any reasons @ 0.5% (Half Percent) of the total value of the item covered in order as LD per week or part thereof subject to a maximum of 10% (Ten Percent) which you unconditionally and expressly agree to unless extension is obtained from BNPM without imposition of LD, without price escalation along with any other denial conditions (if applicable) on valid ground before expiry of delivery period.
6. **Warranty:** The supplier warrants that the goods supplied under the contract is new, unused and shall have no defect arising from design, materials (except when the design adopted and / or the material used are as per BNPM's specifications) or workmanship or from any act or omission of the supplier, that may develop under normal use of the supplied goods under the conditions prevailing in India. This warranty shall remain valid for **Twelve (12) months** after the goods or any portion thereof as per the tender, have been delivered to the final destination and accepted by BNPM. In case of any claim arising out of this warranty, BNPM shall promptly notify the same in writing to the supplier and within a mutually agreed time supplier shall repair or replace the defective goods or parts thereof, free of cost, at the ultimate destination. In case of warranty validity less than specified period, the same may be mentioned in appropriate place given in this document.
7. **Performance Security:-** Performance security has to be submitted by the successful bidder within 21 days from the date of issue of purchase order/contract, whichever is issued earlier for **5% of the contract value** valid up to valid up to sixty days after the date of completion of all contractual obligations by the supplier, including the warranty obligations.

The Performance security shall be denominated in Indian Rupees or in the currency of the contract and shall be in one of the following forms:



SECTION II – TERMS AND CONDITIONS OF THE TENDER

- a. Account Payee Demand Draft drawn on any commercial bank in India, in favour Bank Note Paper Mill India Private Limited payable at Mysuru.
- b. Un-conditional Bank Guarantee issued / confirmed from any of the commercial bank in India as per the format provided in this tender document.
- c. Insurance Surety Bonds.
- d. Fixed Deposit Receipt from a scheduled commercial bank in India lien to BNPM, Mysore
- e. Online payment in an acceptable form.

In the event of any loss due to supplier's failure to fulfil its obligations in terms of the contract, the amount of the performance security shall be payable to BNPM to compensate BNPM for the same.

8. Manufacturer's name and country of origin of materials offered must be clearly specified. Please quote whether your organization is large scale industry or small scale industry. If you are registered with NSIC/MSE/MSI/DGS&D Certificate, please attach UDYAM certificate to the quotation. Mention your registration details (i.e., Company's registration / Certificate of incorporation/Partnership Deed/Any other registration certificate as applicable)
9. Complete details for the offered product must accompany with the quotation. Make/brand of the offered item shall be stated wherever applicable. If you have got any deviation to the material required by us, the same may be shown separately at section-IV: Quality control Requirements of this document. Acceptance of deviation shall be at sole discretion of BNPM.
10. All supplies are subject to inspection and approval before acceptance.
11. BNPMIPL reserves the right to increase/decrease the quantity specified in this enquiry at the time of placement of order at the quoted price.
12. The prices quoted should be firm till the supplies are completed. Rates quoted should be door deliver basis as per price schedule/ price bid at destination including all charges otherwise the quotation will be rejected. Price quoted should be net and valid up to the completion of all contractual obligations.
13. **Evaluation Criteria:**
 - (i) The technical bids shall be opened in the first instance and these bids shall be scrutinized and evaluated by the competent committee/ authority with reference to the parameters prescribed in the tender document. Subsequently, in the second stage the financial bids of only techno-commercially qualified bidders as decided in first stage shall be opened for further scrutiny and evaluation.
 - (ii) **Method of Evaluation:** Evaluation shall be carried out on **overall lowest effective price** (i.e., without GST) quoted by the bidders, unless any other method of evaluation is specifically provided in the enquiry and contract shall be awarded to **overall lowest (L-1) bidder**. The quoted price should be inclusive of P&F, Freight, Transit Insurance and any other charges required for delivery of item to BNPM, Mysuru on F.O.R basis.
 - (iii) **Price Tie:** L1 shall be awarded based on date of incorporation of company, such as proprietorship & partnership firms, date of GST registration & execution of partnership agreement respectively shall be taken as date of incorporation.
 - (iv) All responsive tenderers shall be evaluated as per the terms & conditions of the tender. The basis for arriving at the lowest responsive bidder shall be as per the price quoted for landed cost at Mysuru including GST, packing & forwarding charges, freight, insurance and any other



SECTION II - TERMS AND CONDITIONS OF THE TENDER

charges etc. i.e., as per price schedule/ price bid and input credit shall be deducted to arrive at the effective price. Effective price shall be considered for arriving the lowest responsive bidder.

- (v) Bidder has to mention appropriate HSN code and quote GST rate provided in Price Schedule. In case of any mismatch in HSN code with respect to offered product, same shall be decided in consultation with winning bidder
- (vi) All tenderers should be registered under GST. They should be eligible to pass on input credit. Bid will be evaluated all-inclusive though input credit will be deducted to arrive at the effective cost.

1. The evaluation of tender for three categories of GST registration is provided below:

Particulars	Registered	Compounding	Unregistered*
Basic Price	xxx	xxx	xxx
Add: GST	X	-	X
Add: Cess on GST	xx	-	Xx
Less Input Credit	X	-	X
Total price	Xxx +X+xx -X	xxx	xxx +X+xx -X

*If the bidders participated in a tender is unregistered, the GST shall be payable by the purchaser under reverse charge and shall be added to the quoted rate to arrive at the Gross price and input credit, if any shall be deducted from the total landed cost to arrive at the net comparable price.

14. Payment of GST is primarily the responsibility of the seller and will not be paid unless the percentage value is clearly mentioned in the quotations. If no indication regarding GST is recorded in the quotation, the GST will be considered as included.
15. **Delay in supplier's performance:** Time for and the date specified in the contract or as extended for the delivery of the stores shall be deemed to be the essence of the contract and the supplier shall deliver the goods and perform the services under the contract within the time schedule specified by BNPM in the contract.

Any delay attributable to the supplier in maintaining its contractual obligations towards delivery of goods and performance of services shall render the supplier liable to any or all the following sanctions besides any administrative action such as (a) Imposition of liquidity damages; (b) Termination of contract for default; (c) Forfeiture of performance security.

16. **Extension of Time:** If the contract is delayed in the progress of work by changes ordered in the work, or any clause which BNPM shall decide to justify the delay, then the time of completion shall be extended by a reasonable time.

If at any time during the currency of contract, the supplier encounters conditions hindering timely delivery of the goods and performance of services, the supplier shall promptly inform BNPM in writing about the same and its likely duration and make a request to BNPM for extension of the delivery schedule accordingly. On receiving the supplier's communication, BNPM shall examine the situation as soon as possible and, at its discretion, may agree to extend the delivery schedule, with or without liquidated damages for completion of supplier's contractual obligations by issuing an amendment to the contract.

17. **Risk Purchase Clause:** If the supplier fails to abide by the terms and conditions of the agreement arising out of this enquiry (or) fails to supply the material/service as per the delivery schedule or



SECTION II – TERMS AND CONDITIONS OF THE TENDER

any time repudiates the contract, the purchaser will have the right to,

- a) Procure the tender item/render service from other agencies at the risk and cost of the supplier. The cost difference between the alternative arrangement and existing contract value where the default has been made, will be recovered from the supplier along with the other incidental charges.
- b) In case of procurement through alternative sources, if procurement price is lower than the existing contract value wherein default has been made, in such case no benefit on this account will be passed on to the supplier.

18. **Force Majeure:** In the event of any unforeseen event directly interfering with the supply of stores arising during the currency of the contract, such as war, hostilities, acts of the public enemy, civil commotion, sabotage, fires, floods, explosions, epidemics, quarantine restrictions, strikes, lockouts, or acts of God, the Contractor shall, within a week from the commencement thereof, notify the same in writing to the Purchaser with reasonable evidence thereof. Unless otherwise directed by BNPM in writing, the supplier shall continue to perform its obligations under the contract as far as reasonably practical, and shall seek all reasonable alternative means for performance not prevented by the Force Majeure event. If the force majeure condition(s) mentioned above be in force for a period of 90 days or more at any time, either party shall have the option to terminate the contract on expiry of 90 days of commencement of such force majeure by giving 14 days' notice to the other party in writing. In case of such termination, no damages shall be claimed by either party against the other, save and except those which had occurred under any other clause of this contract prior to such termination.

19. **Fore-Closure Clause:** If at any time during the continuation of this contract, the use of material ordered in this contract is completely banned or due to drastic change in Government policy its use as, raw material is discontinued or is declared hazardous to public health or cause rising to civil commotion, epidemics, wide-spread strikes and 21 days' notice of such eventualities is given by purchaser to the seller, the seller without any right to enforce the contract, will agree to the fore-close the performance of balance portion of this contract and in that event no claim for damages or loss will be lodged against the purchaser.

20. **Obligations by bidders:**

- i) All bidders are obliged under the CIPP (Code of integrity of public procurement) to suo moto proactively declare any conflict of interest (coming under the definition mentioned above under point no (mention sr. no. of conflict of interest), pre-existing or as and as soon as these arise at any stage) in any procurement process or execution of contract. Failure to do so would amount to violation of this Code of Integrity; and
- ii) Any bidder must declare, whether asked or not in a bid document, any previous transgressions of such a Code of Integrity with any entity in any country during the last 1 (One) year of being debarred by any other Procuring Entity. Failure to do so would amount to violation of this code of integrity.

21. **Conflict of Interest:** A bidder shall not have conflict of interest with other bidders. Such conflict of interest can lead to anti-competitive practice to the detriment of BNPM interests. The bidder found to have a conflict of interest shall be disqualified after giving a reasonable opportunity of being heard. A bidder may be considered to have a conflict of interest with one or more parties in this bidding process, if:

- a) they have controlling partner (s) in common; or

SECTION II – TERMS AND CONDITIONS OF THE TENDER

- b) they receive or have received any direct or indirect subsidy/financial stake from any of them;
or
 - c) they have the same legal representative/agent for purposes of this bid;
 - d) they have relationship with each other, directly or through common third parties, that puts them in a position to have access to information about or influence on the bid of another bidder;
or
 - e) Bidder participates in more than one bid in this bidding process. Participation by a bidder in more than one bid will result in the disqualification of all bids in which the parties are involved. However, this does not limit the inclusion of the components/sub-assembly/assemblies from one bidding manufacturer in more than one bid.
 - f) In cases of agent's quoting in offshore procurements, on behalf of their principal manufacturers, one agent cannot represent two manufacturers or quote on their behalf in a particular tender enquiry. One manufacturer can also authorize only one agent/dealer. There can be only one bid from the following:
 - i. The principal manufacturer directly or through one Indian agent on his behalf; and
 - ii. Indian/foreign agent on behalf of only one principal.
 - g) A Bidder or any of its affiliates participated as a consultant in the preparation of the design or TS of the contract that is the subject of the bid;
 - h) In case of a holding company having more than one independently manufacturing units, or more than one unit having common business ownership/management, only one unit should quote. Similar restrictions would apply to closely related sister companies. Bidders must proactively declare such sister/ common business/ management units in same/ similar line of business.
 - i) In the event of the bidder having any conflict of interest, such bidder is obligated to disclose the same to BNPM. Failure to do so will disqualify the bidder.
22. Counter conditions (if any on technical & commercial terms) shall be reviewed by BNPM and acceptance of the same shall be at sole discretion of BNPM.
23. Bidders are advised to write the page number on each page of the Technical Bid documents submitted.
24. The BNPMIPL reserves the right to accept the offer by individual items and reject any or all tenders without assigning any reason thereof and does not bind itself to accept lowest quotations.
25. **Divisibility & split-ability of contract:** This clause shall be governed by conditions as specified in clause (13) of this tender.
26. **Settlement of Disputes through Arbitration:** All disputes and differences of any kind whatsoever arising out of or in connection with the contract, whether during the progress of the work or after their completion except accepted matters shall be settled through arbitration process as per the Arbitration & Conciliation Act, 1996. The venue of arbitration shall be Mysuru, Karnataka.
27. **Legal Jurisdiction:** The Courts of Mysuru (Karnataka State) shall alone have jurisdiction to decide on any legal matter of dispute whatsoever arising out or in respect of the contract.
28. **Rights of Rejection:** BNPMIPL reserves the right to reject any or all the applied bids without assigning any reason whatsoever. The enquiry can be rejected on national security grounds.

SECTION II – TERMS AND CONDITIONS OF THE TENDER

29. **Preference for Micro and Small Enterprises (*MSEs):** Public procurement policy for Micro and Small Enterprises (MSEs) order, 2012 as notified by Govt of India (GOI) along with its amendments as available in www.msme.gov.in shall be applicable to this tender.

I/we engage to supply the material(s) to your engineering store, BNPMIPL and comply the following:

1. Tender schedule and technical specification indicated.
2. Item/tender specific conditions for this tender.
3. Terms and conditions of this tender.
4. I/we confirm that set off for the GST, etc. paid on the inputs have been taken into consideration in the above quoted price and further agree to pass on such additional duties as sets offs as may become available in future under GST, etc.
5. This offer is **valid for 90 (Ninety) days** from the date of opening of the tender.
6. That we have not been debarred by BNPMIPL/BRBNMPL/SPMCIL and any other Government/ Undertakings (Annexure-B enclosed).

Signature & Seal: Place & Date:		Name of Authorized Signatory:	
Address:		Tel. No./Fax. No./Mobile No. Email Id:	



SECTION III – TECHNICAL SPECIFICATIONS

S No	Item	Technical Specification
1.	Dead (Counter) Knife for Bale press,	Drg No :BNPM/FH/323/2024-25, MOC: HSS (M2 Grade)
2.	Movable center Knife for Bale press	Drg No :BNPM/FH/324/2024-25, MOC: HSS (M2 Grade)
3.	Movable Left side Knife for Bale press	Drg No :BNPM/FH/325/2024-25, MOC: HSS (M2 Grade)
4.	Movable right side Knife for Bale press	Drg No :BNPM/FH/326/2024-25, MOC: HSS (M2 Grade)

Scope of Supply:

1. Vendor should have facility to manufacture Knives at their own workshop. If required BNPM will visit vendor facility to ensure the availability of required facilities.
2. Vendor need to submit the Dimensional report and material test MOC certificate (either from Material OEM or NABL approved lab) to BNPM along with material supply. If required BNPM will also counter check the same from the supplied material.
3. Vendor need to offer inspection call for the 1st number of each item of Purchase order for checking (within 7 km radius from BNPM). Other vendors need to supply one number in each item of purchase order for inspection at BNPM.
4. If the item is not made as per Purchase order specification, it is the vendor's responsibility to repeat the same and to confirm Purchase order specification. This entire sample process to be completed within 60 days from the receipt of purchase order.
5. BNPM will give the clearance of inspection by mail to the successful bidder within 7 days from the date of inspection call/ receipt of sample mentioned at BNPM.
6. After getting the inspection clearance from BNPM, the vendors can start manufacture the remaining items with any corrections required by BNPM. Vendor should supply remaining materials within 60 days after BNPM clearance.
7. On inspection of remaining material, if any deviation is found from the accepted sample, then new material need to supplied by vendors and then only rejected lot will be permitted to taken out from BNPM.



SECTION III – TECHNICAL SPECIFICATIONS

8. Item should have the warranty period of minimum 12 months from the date of material supply.
9. Payment will be made only after supplying the complete Purchase order quantity and acceptance of the same.

(To be signed & stamped and submitted along with Techno-commercial Bid Part –I)



SECTION III - TECHNICAL SPECIFICATIONS

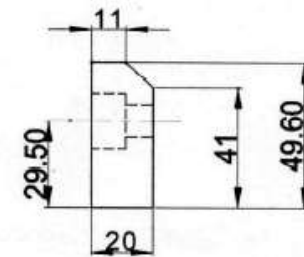
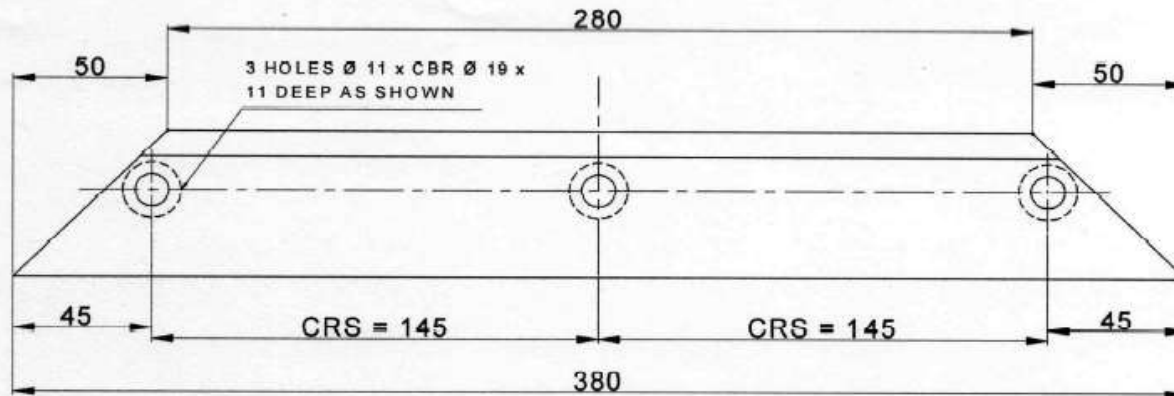

 BANK NOTE PAPER MILL INDIA PRIVATE LIMITED MYSORE - 570003			
BANK NOTE PAPER MILL INDIA PRIVATE LIMITED		BALE PRESS DEAD KNIFE	
PREPARED BY	<i>[Signature]</i>	DATE	25-11-24
CHECKED BY	<i>[Signature]</i>	DATE	25/11/24
APPROVED BY	<i>[Signature]</i>	DATE	25/11/24
			MOC: HSS (M2)
			DRG.NO:BNPM / FH / 323 / 2024-25



SECTION III - TECHNICAL SPECIFICATIONS

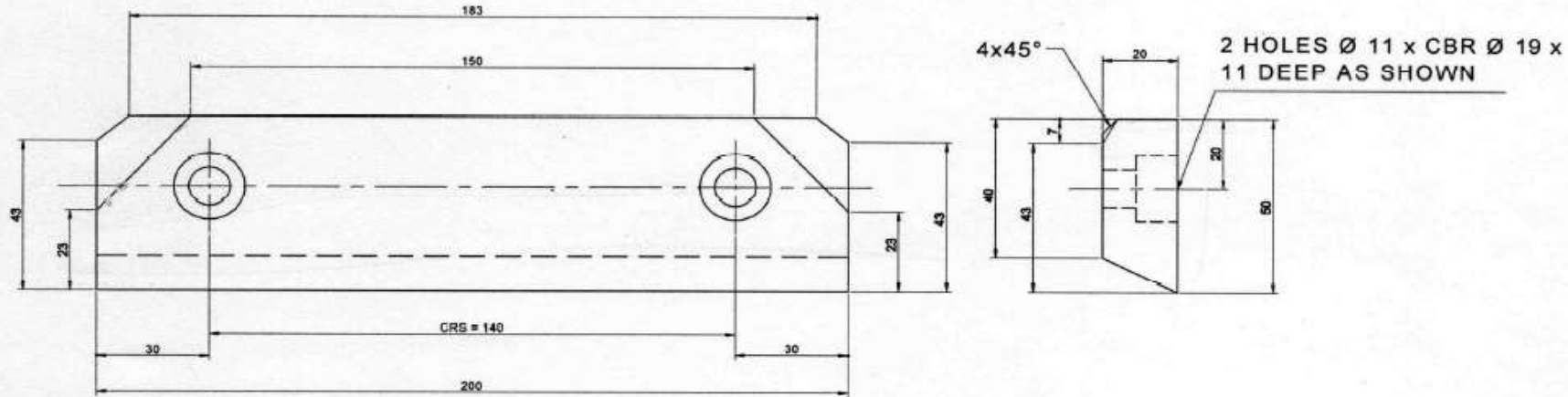



 BANK NOTE PAPER MILL INDIA PRIVATE LIMITED MYSORE - 570003			
	SIGNATURE	DATE	BALE PRESS MOVEABLE KNIFE - CENTRE
PREPARED BY	<i>[Signature]</i>	25.11.24	MOC : HSS (M2)
CHECKED BY	<i>[Signature]</i>	25/11/24	
APPROVED BY	<i>[Signature]</i>	25/11/24	DRG. NO:BNPM/FH/324/2024-25

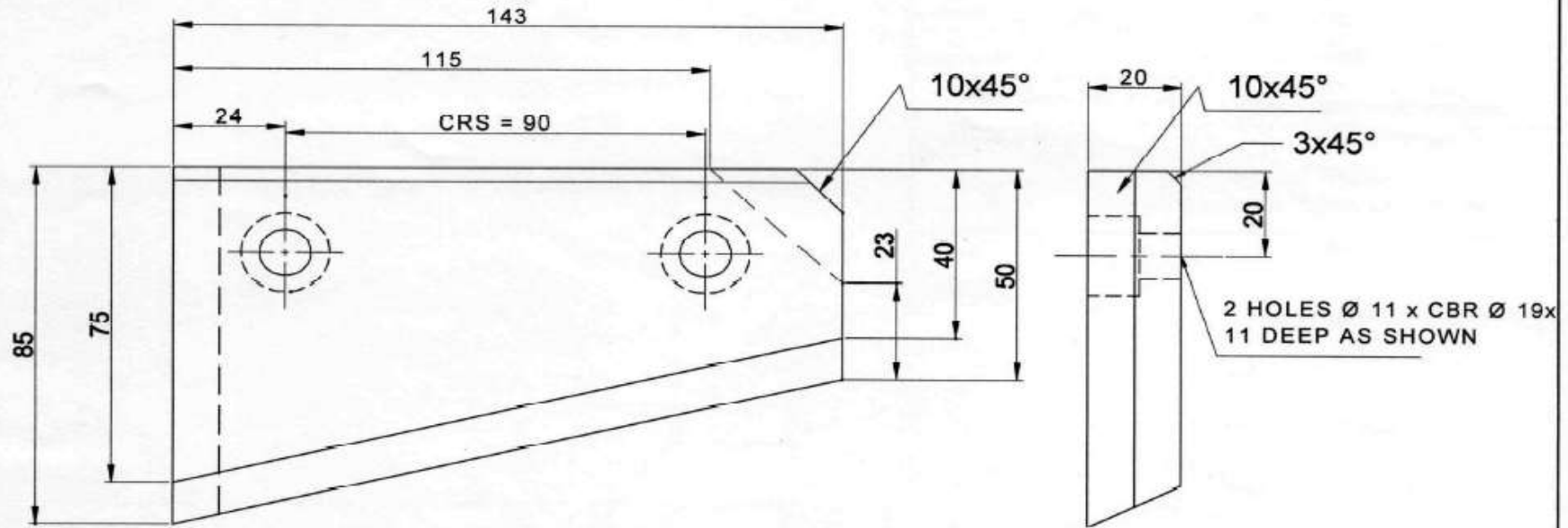

SECTION III - TECHNICAL SPECIFICATIONS

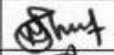

 BANK NOTE PAPER MILL INDIA PRIVATE LIMITED MYSORE - 570003		BANK NOTE PAPER MILL INDIA PRIVATE LIMITED MYSORE - 570003	
	SIGNATURE	DATE	Bale press Movable Knife - Left side
PREPARED BY		25.11.24	MOC : HSS (M2) DRG.No: BNPM/FH/325/2024-25
CHECKED BY		25/11/24	
APPROVED BY		25/11/24	



SECTION III - TECHNICAL SPECIFICATIONS

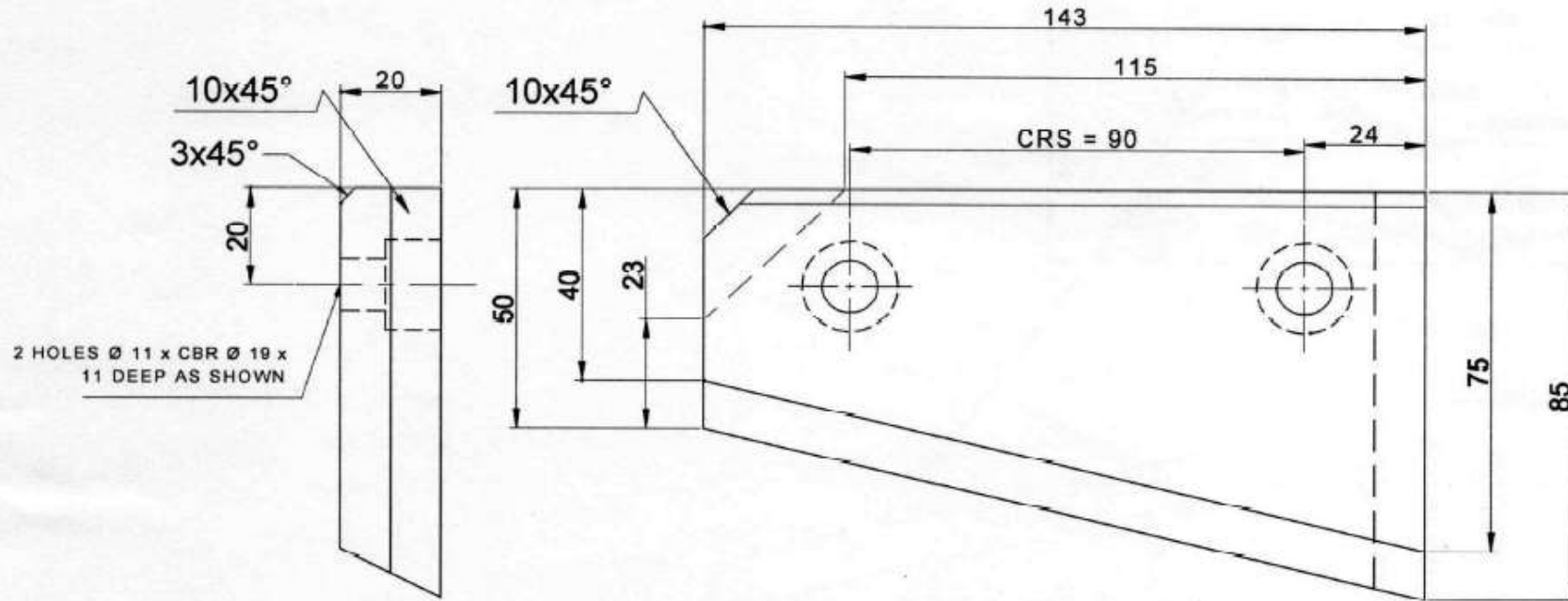

		BANK NOTE PAPER MILL INDIA PRIVATE LIMITED MYSORE - 570003	
BANK NOTE PAPER MILL INDIA PRIVATE LIMITED			
	SIGNATURE	DATE	Bale press Movable knife - Right side MOC: HSS (M2) DRG,NO:BNPM/FH/326/2024-25
PREPARED BY	<i>[Signature]</i>	25-11-24	
CHECKED BY	<i>[Signature]</i>	25/11/24	
APPROVED BY	<i>[Signature]</i>	25/11/24	



SECTION IV – QUALITY CONTROL REQUIREMENTS

1. **Quality:** Quality is essence of this tender. The bidder shall supply the material as per the specifications mentioned in Technical Specifications. The material supplied will be inspected at our factory. Quantity as ascertained on receipt of above material at our site will be treated as quantity supplied wherever the package/materials are received intact.

2. **Rejection:** Materials not meeting our specification will be rejected outright and the rejected material shall be taken back within 7 days at the cost and risk of the supplier and replacement should be made within 15 days from the date of intimation. No payment shall be made for rejected item.

A) Eligibility Criteria:

S. No	Item Description	Whether agreed by the bidder	Deviation if any
1	Bidder should be either Original Equipment Manufacturer (OEM) or authorized dealer/ distributor/ representative of the OEM manufacturing the tendered product. (Copy of Manufacturers declaration (OEM) /Authorized Dealer /Distributor Certificate issued by the OEM	Submitted/ Not Submitted	
2	Bidder should have supplied at least 4 No's of knives in any one year of last 5 years ending on 30.11.2024. (Copy of purchase orders & Documents evidencing supply of material (viz. LR/E-way bill/GSTR etc).	Submitted/ Not Submitted	

A) TECHNICAL COMPLIANCE STATEMENT:

S No	Required Specifications	Whether agreed by the bidder	Deviations (if any)
1.	Dead (Counter) Knife for Bale press, Drg No :BNPM/FH/323/2024-25, MOC: HSS (M2 Grade)	Yes Agreed	
2.	Movable centre Knife for Bale press Drg No: NPM/FH/324/2024-25 ; MOC: HSS (M2 Grade)	Yes Agreed	
3.	Movable Left side Knife for Bale press Drg No BNPM/FH/325/2024-25, MOC: HSS (M2 Grade)	Yes Agreed	
4.	Movable right side Knife for Bale press Drg No :BNPM/FH/326/2024-25, MOC: HSS (M2 Grade)	Yes Agreed	



SECTION IV – QUALITY CONTROL REQUIREMENTS

5.	Detailed scope of supply as per tender section III (Technical specifications)	Yes Agreed	
<i>(Acceptance to deviations shall be at sole discretion of BNPM. In case of non-acceptance of deviations, bid is liable to be rejected. Interested bidders may get pre-clarifications to technical deviations from BNPM prior to submission of bid to avoid rejection of bids at a later stage.)</i>			

B) COMMERCIAL COMPLIANCE STATEMENT

Sl. No.	Features	Requirements of BNPMIPL, Terms & conditions	Whether Agreed by the firm	Deviation, if any
1.	Payment Terms	As mentioned in Sl.No.3 of Section II	Yes agreed	
2.	Liquidated Damages	As mentioned in Sl.No.5 of Section II	Yes agreed	
3.	Warranty Period	As mentioned in Sl.No.6 of Section II	Yes agreed	
4.	Performance Security	As mentioned in Sl.No.7 of Section II	Yes agreed	
5.	Risk Purchase	As mentioned in Sl No.17 of Section II	Yes agreed	
6.	All other terms & conditions as mentioned in tender		Yes agreed	
7.	No. of pages	Total number of pages in Technical Bid		

SECTION V - DECLARATIONS

ANNEXURE -A

e-Tender No: BNPM/OTE/445/2024-25 dated 27.12.2024.

- I) *Any bidder from a country which shares a land border with India will be eligible to bid in the tender only if the bidder is registered with the Competent Authority (The Registered Committee constituted by the Department for Promotion of Industry and Internal Trade).
- II) Bidder means any person or firm or company, including any member of a consortium or joint venture (that is an association of several persons, or firms, or companies), every artificial judicial person not falling in any of the descriptions of bidders stated hereinbefore, including any agency branch or office controlled by such person participating in a procurement process.
- III) "Bidder from a country which shares a land border with India" for the purpose of this order means:-
- a) An entity incorporated, established or registered in such a country; or
 - b) A subsidiary controlled through entities incorporated, established or registered in such a country, or
 - c) An entity substantially controlled through entities incorporated, established or registered in such a country, or
 - d) An entity whose beneficial owner is situated in such a country; or
 - e) An India (or other) agent of such an entity; or
 - f) A natural person who is a citizen of such a country; or
 - g) A consortium or joint venture where any member of the consortium or joint venture falls under any of the above.
- IV) The beneficial owner for the purpose of (iii) above will be as under:-
- 1) In case of a company or limited liability partnership, the beneficial owner is the natural person (s), who, whether acting alone or together, or through one or more judicial person, has a controlling ownership interest or who exercise control through other means.
- Further explanation:
- a) "Controlling ownership interest" means ownership of or entitlement to more than twenty five per cent of shares or capital or profits of the company;
 - b) "Control" shall include the right to appoint majority of the director or to control the management or policy decision including by virtue of their shareholding or management rights or shareholder agreements or voting agreements;
- 2) In case of partnership firm, the beneficial owner is the natural person(s) who, whether acting alone or together, or through one or more judicial person, has ownership of entitlement to more than fifteen percent of capital or profits of the partnership;
 - 3) In case of an unincorporated association or body of individuals, the beneficial owner is the natural person(s), who , whether acting alone or together, or through one or more judicial person, has ownership of or entitlement to more than fifteen percent of the property or capital or profits of such association or body of individuals;



SECTION V - DECLARATIONS

- 4) Where no natural person is identified under (1) or (2) or (3) above, the beneficial owner is the relevant natural person who holds the position of senior managing official;
- 5) In case of a trust, the identification of beneficial owners(s) shall include identification of the author of the trust, the trustee, the beneficiaries with fifteen percent or more interest in the trust and any other natural person exercising ultimate effective control over the trust through a chain of control or ownership.
- V) An agent is a person employed to do any act for any another, or to represent another in dealings with third persons.
- VI) The successful bidder shall not be allowed to sub contract works to any contractor from a country which shares a land border with India unless such contractor is registered with the Competent Authority.
- VII) A bidder is permitted to procure raw material, components, sub-assemblies etc. from the vendors from countries which shares a land border with India. Such vendors will not be required to be registered with the competent authority, as it is not regarded as sub-contracting.
- VIII) However, in case a bidder has proposed to supply finished goods procured directly/indirectly from the vendors from the countries sharing land border with India, such vendor will be required to be registered with the competent authority.
- IX) The registration shall be valid at the time of submission of bid and at the time of acceptance of bid.

I have read the above clause regarding restrictions on procurement from a bidder of a country which shares a land border with India. I hereby certify that M/s is not from such a country or, if from such a country, has been registered with the Competent Authority. I hereby certify that M/s fulfills all requirements in this regard and is eligible to be considered." (where applicable, evidence of valid registration by the Competent Authority shall be attached)

I, the undersigned, declare that the item originate in (Name of the country).

Signature: _____

Name: _____

Designation: _____

Date: _____

Stamp of the Organization:



SECTION V - DECLARATIONS

ANNEXURE -B

e-Tender No: BNPM/OTE/445/2024-25 dated 27.12.2024.

(To be submitted on the letterhead)

DECLARATION

We do hereby declare that,

1. As on the date of submission of bid against this tender, we are not in the list of ineligible/ blacklisted/ banned/ debarred entity by SPMCIL/ BRBNMPL/ BNPMIPL/any government agency for participating in its tenders.

Further, we agree, in case we got blacklisted/ banned/ debarred by SPMCIL/ BRBNMPL/ BNPMIPL/any Government Agency, any time prior to finalization of tender/ contract, our bid shall not be considered for further evaluation/ award of order.

2. We do hereby declare that we have read and understood all terms and conditions of tender document including Technical Specification, Quality Control Criteria and confirm to abide to those conditions without any counter conditions.
3. The director/proprietor of the bidding firm are not closely related to BNPMIPL.

In case, at any time the information furnished is found to be false, you may disqualify/ debar me/ us as deemed fit.

Signature: _____

Name: _____

Designation: _____

Date: _____

Stamp of the Organization:



SECTION V - DECLARATIONS

ANNEXURE C

BID SECURITY DECLARATION

e-Tender No: BNPM/OTE/445/2024-25 dated 27.12.2024.

(To be submitted on the letterhead)

We, the undersigned, declare that we will automatically be suspended from being eligible for bidding in any tender with Bank Paper Mill India Private Limited, Mysuru for the period of 12 months, if we are withdrawing our Bid during the period of bid validity (or) fail / refuse to furnish the performance security / execute the contract, if awarded.

Signature: _____

Name: _____

Designation: _____

Date: _____

Stamp of the Organization:

SECTION VI – PRICE BID FORMAT

(TO BE FILLED ONLINE THROUGH E-TENDER PORTAL)

Dear Sir,

Sub: PRICE BID FOR SUPPLY OF KNIFES FOR BALE PRESS AT BNPM PLANT, MYSURU.

Ref: e-Tender No: BNPM/OTE/445/2024-25 dated 27.12.2024.

We have received and understood the above tender enquiry and are pleased to submit our price bid as under:

Sch. No.	Description	HSN	Qty	UOM	Basic Unit price (INR)	P&F, Freight & Transit Insurance & any other charges (if any) per unit (INR)	Unit Price (incl. of P&F, Freight, Transit Insurance & any other charges (if any) excl. of GST) (INR)	GST (%)	GST on Unit Price (INR)	Total Unit Price (incl. of GST) (INR)	Less: Input Credit (GST) (INR)	Effective Unit Price (net of input tax credit) (F.O.R Mysuru) (INR)	Total Effective price (net of input tax credit) (F.O.R Mysuru) (INR)
			A		B	C	D=B+C	E	F=D*E	G=D+F	H=F	I=G-H	J=I*A
1.	Dead (Counter) Knife for Bale press, Drg No :BNPM/FH/323/2024-25, MOC: HSS (M2 Grade)		4	Nos									
2.	Movable centre Knife for Bale press Drg No: NPM/FH/324/2024-25 ; MOC: HSS (M2 Grade)		4	Nos									

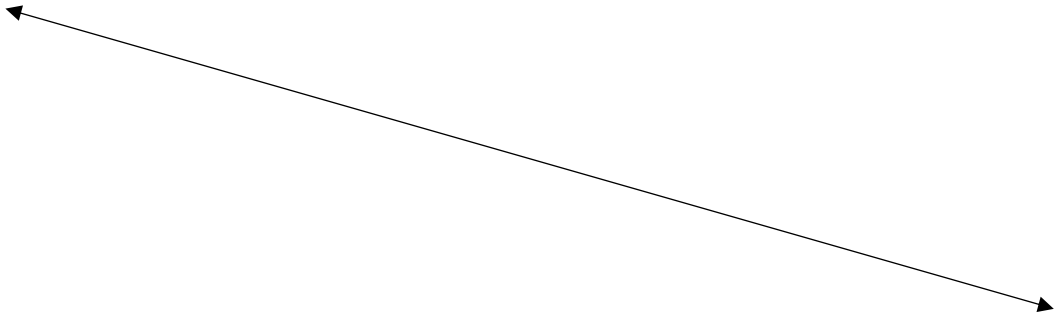

SECTION VI – PRICE BID FORMAT

3.	Movable Left side Knife for Bale press Drg No BNPM/FH/325/2024-25, MOC: HSS (M2 Grade)		2	Nos	
4.	Movable right side Knife for Bale press Drg No :BNPM/FH/326/2024-25, MOC: HSS (M2 Grade)		2	Nos	

Note: Prices quoted above shall be F.O.R – BNPM, Mysuru site basis inclusive of GST, Packing & Forwarding charges, freight, transit insurance and all other charges if applicable.

Price Discrepancy:

- i. If, in the price structure quoted by a tenderer, there is discrepancy between the unit price and the total price (which is obtained by multiplying the unit price by the quantity), the unit price shall prevail and the total price corrected accordingly, unless BNPM feels that the tenderer has made a mistake in placing the decimal point in the unit price, in which case the total price as quoted shall prevail over the unit price and the unit price corrected accordingly.
- ii. If there is an error in a total price, which has been worked out through addition and/ or subtraction of subtotals, the subtotals shall prevail and the total corrected; and
- iii. If there is a discrepancy between the amount expressed in words and figures, the amount in words shall prevail.
- iv. If, as per the judgment of BNPM, there is any such arithmetical discrepancy in a tender, the same will be suitably conveyed to the tenderer by registered/speed post. If the tenderer does not agree to the observation of BNPM, the tender is liable to be ignored.

Seal ()

Name

Signature with Date

Note: i) Price should be quoted exactly as per the format given above; Price bids with conditions / Counter conditions are liable for rejection.
ii) Multiple / Variable rate for single item, would lead to rejection of offer.

SECTION VII - BANK GUARANTEE FORM FOR PERFORMANCE SECURITY

..... (Insert: Bank's Name, and Address of Issuing Branch or Office)

Beneficiary:

Bank Note Paper Mill India Private Limited
Administrative Building, Entry Gate 1,
Paper Mill Compound, Note Mudran Nagar,
Mysuru - 570003
Date:

Performance Guarantee No.:

WHEREAS.....(name and address of the supplier) (hereinafter called "the supplier") has undertaken, in pursuance of PO (Purchase order) no..... dated to supply (description of goods and services) (herein after called "the contract").

AND WHEREAS it has been stipulated by you in the said PO that the supplier shall furnish you with a bank guarantee by a scheduled commercial bank recognized by you for the sum specified therein as security for compliance with its obligations in accordance with the PO;

AND WHEREAS we have agreed to give the supplier such a bank guarantee;

NOW THEREFORE we hereby affirm that we are guarantors and responsible to you, on behalf of the supplier, up to a total of..... (amount of the guarantee in words and figures), and we undertake to pay you, upon your first written demand declaring the supplier to be in default under the contract and without cavil or argument, any sum or sums within the limits of (amount of guarantee) as aforesaid, without your needing to prove or to show grounds or reasons for your demand or the sum specified therein.

We hereby waive the necessity of your demanding the said debt from the supplier before presenting us with the demand. We further agree that no change or addition to or other modification of the terms of the contract to be performed thereunder or of any of the contract documents which may be made between you and the supplier shall in any way release us from any liability under this guarantee and we hereby waive notice of any such change, addition or modification.

We undertake to pay Bank Note Paper Mill India Private Limited up to the above amount upon receipt of its first written demand, without Bank Note Paper Mill India Private Limited having to substantiate its demand.

This guarantee will remain in force for a period of sixty days after the currency of this contract and any demand in respect thereof should reach the Bank not later than the above date.

(Signature of the authorized officer of the Bank)

Name, Authorization/ Signature no. and Designation of the officer

Seal, Name & Address of the Bank and Address of the Branch

SECTION VII - BANK GUARANTEE FORM FOR PERFORMANCE SECURITY

Checklist for Bank Guarantee:

Performance BG should be in line with / comply to the following.

1. BG should be issued on not less than Rs. 300/- e-stamp / non-judicial stamp paper in case of paper Bank Guarantees (or) not less than Rs. 200/- e-stamp in case of e-Bank Guarantees.
2. Non judicial stamp paper / e stamp paper should be purchased in the name of BG issuing bank only.
3. In case of e stamp paper first party should be BG issuing bank and second party should be BNPM.
4. Date of sale of non-judicial / e stamp paper shown on the BG and the stamp paper (BG) issued is not more than six months prior to the date of execution of BG.
5. Executing officer of BG should indicate his name, designation and power of attorney number / signing power no etc. on each page of BG.
6. Name and address of the supplier, name and address of BNPM and value are to be mentioned clearly.
7. Overwriting / cutting if any in BG should be authenticated under signature and seal of authorized signatory of BG issuing Bank.
8. BG number and BG date should be mentioned in all pages of BG and all pages are endorsed / signed by authorized signatories of issuing bank.
9. Amount mentioned in figures and words are to be matched.
10. Validity of BG should be in line with the contract.
11. BG should be unconditional.
12. Our Bank details is mentioned below:

Name of the Bank: HDFC Bank

Name of the Branch: Richmond Road Branch

Branch Address: No. 8/24, Salco Centre, Bangalore- 560025, Karnataka

IFSC: HDFC0000523