

**Not Transferable
Security Classification: Non-Security**



बैंक नोट पेपर मिल इण्डिया प्रा. लिमिटेड
BANK NOTE PAPER MILL INDIA PVT LIMITED
JV of SPMCIL - A Govt. of India Enterprises & BRBNMPL - A Subsidiary of RBI

TENDER ENQUIRY FOR REPLACEMENT OF VACUUM SEPERATOR TANK AT BNPM, MYSORE

This tender document contains 18 Pages

Tender Enquiry No.	BNPM/OTE/198/2024-25
Tender issuing date	17.07.2024
Pre-bid meeting date & time	Not Applicable
Due date & time for bid submission	07.08.2024 till 1100 Hrs.
Mode of bid submission	Online
Type of tender	OPEN TENDER ENQUIRY (OTE)
Tender Processing Fee	Rs. 250/- + Taxes
Details of contact person	Assistant General Manager (SCM) 0821-240111/181/184/177

Registered & Corporate Office:
Administrative Building
Gate 1, Paper Mill Compound
Note Mudran Nagar, Mysuru - 570 003
Telephone No. 0821 - 2401 111

e-mail: scm.tender@bnpmindia.com

website: www.bnpmindia.com



List of Contents

Section I	Notice Inviting Tender	Enclosed
Section II	Terms and Conditions	Enclosed
Section III	Technical Specifications	Enclosed
Section IV	Quality Control Requirements & Compliance Statement	Enclosed
Section V	Declarations	
	Annexure - A , A1	Enclosed
	Annexure -B	Enclosed
	Annexure - C	Enclosed
Section VI	Price Bid format	Enclosed
Section VII	Bank Guarantee format	Enclosed



SECTION I: NOTICE INVITING TENDERS

1. E-tenders are invited from eligible and qualified tenderers for supply of following goods:

Schedule No.	Brief Description of Goods / Services	EMD**	Required Quantity (Nos)*
1	REPLACEMENT OF VACUUM SEPERATOR TANK AT BNPM, MYSORE	Rs. 2,500/-	2 No's

**For MSE Bidders: Submission of EMD is exempted for Micro and small enterprises (MSEs) as per the Public Procurement Policy for MSEs Order, 2012. MSEs should be registered and also will continue to remain registered during the tender validity period with District Industries Centre (DIC) or Khadi and Village Industries Commission (KVIC) or Khadi and Industries Board (KVIB) or Coir Board or National Small Industries Commission (NSIC) or Directorate of Handicrafts and Handlooms or UDYAM Registered or Any other body specified by Ministry of MSME. Document: Valid NSIC / KVIC / KVIB / DIC / UDYAM Registration certificate and Bid Security Declaration as per Annexure C is to be submitted by MSE bidders for EMD exemption. For Non MSE bidders: Declaration for being non MSE and confirmation for submission of EMD may be submitted.

2. Procedure for bid submission:

- a) Interested bidders may obtain further information about this requirement from the above office selling the documents. They may also visit our website www.tenderwizard.com/BNP mentioned above for further details.
 - b) Aspiring Bidders/Contractors who have not registered in e-tendering should register through the website E - Tendering (www.tenderwizard.com/BNP) for participating in the Online Tenders. The registration charges will be Rs. 500/- plus applicable taxes (per year) which needs to be paid through electronic mode only.
 - c) For details, registration and e-payment, please visit e-tendering website www.tenderwizard.com/BNP or contact KEONICS help desk @ 8951906455.
 - d) Class III Digital Signature Certificate (DSC) is mandatory to participate in e-Tenders. Participating bidders/Contractors have to make sure that they have the valid DSC. If not, they can procure from any of the firm as approved by CCA.
3. The tenderer shall satisfy BNPMIPL that they are competent and authorized to submit tender and/or to enter into a legally binding contract with the BNPMIPL. To this effect, any person giving a tender shall render documentary evidence that his signature on the tender submitted by him is legally binding upon himself, his firm or company as the case may be.
 4. For those tenderers whose technical bids do not satisfy the eligibility criteria, their financial Bids will not be opened.
 5. In the event of any of the above-mentioned dates being declared as a holiday/ closed day for the purchase organization, the tenders will be sold / received / opened on the next working day at the appointed time.
 6. BNPM reserves the right to cancel the tender at any stage without assigning the reasons thereof.

Yours faithfully,

For and on behalf of BNPMIPL

Assistant General Manager



SECTION II: TERMS AND CONDITIONS OF TENDER

1. Tenders are to be uploaded on e-tendering portal www.tenderwizard.com/BNP only in two- part bid system.
2. **Part-I – Prequalification Bid & Techno-commercial Bid:** Scanned copy of Technical offer (catalogue/brochure etc.), GST, PAN, Bank details etc. along with all sections & annexures of this tender.
 - ii) **Part II – Price Bid:**
Price shall be furnished through e-portal only.
Price offer submitted in any other format will be liable for rejection.
3. **Payment terms:**
100% payment shall be released within 30 days after successful completion of the work and duly certified by BNPM officials after submission of bill.
4. **Work Schedule:** Successful contractor shall complete the work during specific date as promulgated by BNPM, Mysore.
5. **Contract period validity:** The contract shall be valid for a period of Nine (09) months from the date of issue of work order.
6. **Liquidated Damage:** In case your quotation is accepted and order is placed on you, the supply against the order should be made within the period stipulated in the order. BNPMIPL reserves the right to recover any loss sustained due to delayed delivery by way of penalty. Failure to supply the material within the stipulated period shall entitle BNPM to impose liquidated damages without assigning any reasons @ 0.5% (Half Percent) of the total value of the item covered in order as LD per week or part thereof subject to a maximum of 10% (Ten Percent) which you unconditionally and expressly agree to unless extension is obtained in writing from the office on valid ground before expiry of delivery period.
7. **Warranty:** NA
8. **Security Deposit / Performance Security:** NA
9. Manufacturer's name and country of origin of materials offered must be clearly specified. Please quote whether your organization is large scale industry or small scale industry. If you have NSIC/MSE/MSI/DGS&D Certificate, please attach it to the quotation. Mention your registration details.
10. All drawings sketches and samples, if any, sent along with this enquiry must be returned along with quotations duly signed.
11. All supplies are subject to inspection and approval before acceptance. Manufacturer/ supplier warranty certificates and manufacturer/Government approved lab test certificate shall be furnished along with the supply, wherever applicable.
12. The BNPMIPL reserves the right to modify the quantity specified in this enquiry.



SECTION II: TERMS AND CONDITIONS OF TENDER

13. The prices quoted should be firm till the supplies are completed. Please quote the rates in words and figures. Rates quoted should be door deliver basis at destination including all charges otherwise the quotation is likely to be rejected. Prices quoted for free delivery at destination (i.e., Mysore) will be given preference. If there is no indication regarding the FOR, in the quotation, then it will be considered as FOR destinations. Price quoted should be net and valid for a minimum period of three months from the date of opening of the quotation.

14. Evaluation Criteria:

- i) The technical bids shall be opened in the first instance and these bids shall be 5scrutinized and evaluated by the competent committee/ authority with reference to the parameters prescribed in the tender document. Subsequently, in the second stage the financial bids of only technically acceptable offers as decided in first stage shall be opened for further scrutiny and evaluation. Intimation regarding opening of financial bids shall be given to acceptable tenderers to enable them to attend the financial bid opening, if they so desire.
- ii) **Method of Evaluation:** Evaluation shall be carried out on **total effective price** quoted by the bidders, unless any other method of evaluation is specifically provided in the enquiry and contract shall be awarded to **overall lowest (L-1) bidder**. The quoted price should be inclusive of P&F, Freight, Transit Insurance and any other charges required for delivery of item to BNPM, Mysuru on F.O.R basis.
- iii) All responsive tenderers shall be evaluated as per the terms & conditions of the tender. The basis for arriving at the lowest responsive bidder shall be as per the price quoted for landed cost at Mysore including GST, packing & forwarding charges, freight, insurance and any other charges etc. and input credit shall be deducted to arrive at the effective price. Effective price shall be considered for arriving the lowest responsive bidder.
- iv) Bidder has to quote GST rate as per the HSN code provided in Section XI: Price Schedule. In case of any mismatch in HSN code with respect to offered product, same shall be decided in consultation with winning bidder.
- v) All tenderers should be registered under GST. They should be eligible to pass on input credit. Bid will be evaluated all-inclusive though input credit will be deducted to arrive at the effective cost.

1. The evaluation of tender for three categories of GST registration is provided below:

Particulars	Registered	Compounding	Unregistered*
Basic Price	Xxx	Xxx	Xxx
Add: GST	X	-	X
Add: Cess on GST	Xx	-	Xx
Less Input Credit	X	-	x
Total price	Xxx +X+xx -X	xxx	xxx +X+xx -X

*If the bidders participated in a tender is unregistered, the GST shall be payable by the purchaser under reverse charge and shall be added to the quoted rate to arrive



SECTION II: TERMS AND CONDITIONS OF TENDER

at the Gross price and input credit, if any shall be deducted from the total landed cost to arrive at the net comparable price.

- 15.** Payment of GST is primarily the responsibility of the seller and will not be paid unless the percentage value is clearly mentioned in the quotations. If no indication regarding GST is recorded in the quotation, the GST will be considered as included.
- 16.** If the supplier fails to abide by the terms and conditions of the agreement arising out of this enquiry (or) fails to supply the material/service as per the delivery schedule or any time repudiates the contract, the purchaser will have the right to,
- Procure the tender item/render service from other agencies at the risk and cost of the supplier. The cost difference between the alternative arrangement and existing contract value where the default has been made, will be recovered from the supplier along with the other incidental charges.
 - In case of procurement through alternative sources, if procurement price is lower than the existing contract value wherein default has been made, in such case no benefit on this account will be passed on to the supplier.
- 17. Risk Purchase Clause:** If the supplier fails to abide by the terms and conditions of this agreement, or fails to supply the material / service as per the delivery schedule or any time repudiates the contract, the purchaser will have the right to
- Procure the tender item / render service from other agencies at the risk and cost of the supplier.
 - The cost difference between the alternative arrangement and existing contract value wherein default has been made will be recovered from the supplier along with the other incidental charges.
In case of procurement through alternative sources, if procurement price is lower than the existing contract value wherein default has been made, in such case no benefit on this account will be passed on to the supplier.
- 18. Settlement of Disputes through Arbitration:** All disputes and differences of any kind whatsoever arising out of or in connection with the contract, whether during the progress of the work or after their completion except accepted matters shall be settled through arbitration process as per the Arbitration & Conciliation Act, 1996. The venue of arbitration shall be Mysore, Karnataka
- 19. Legal Jurisdiction:** The Courts of Mysore (Karnataka State) shall alone have jurisdiction to decide on any legal matter of dispute whatsoever arising out or in respect of the contract.
- 20. Force Majeure:** In the event of any unforeseen event directly interfering with the supply of stores arising during the currency of the contract, such as war, hostilities, acts of the public enemy, civil commotion, sabotage, fires, floods, explosions, epidemics, quarantine restrictions, strikes, lockouts, or acts of God, the Contractor shall, within a week from the commencement thereof, notify the same in writing to the Purchaser with reasonable evidence thereof. Unless otherwise directed by BNPM in writing, the supplier shall continue to perform its obligations under the contract as far as reasonably practical, and



SECTION II: TERMS AND CONDITIONS OF TENDER

shall seek all reasonable alternative means for performance not prevented by the Force Majeure event. If the force majeure condition(s) mentioned above be in force for a period of 90 days or more at any time, either party shall have the option to terminate the contract on expiry of 90 days of commencement of such force majeure by giving 14 days' notice to the other party in writing. In case of such termination, no damages shall be claimed by either party against the other, save and except those which had occurred under any other clause of this contract prior to such termination.

- 21. Fore-Closure Clause:** If at any time during the continuation of this contract, the use of material ordered in this contract is completely banned or due to drastic change in Government policy its use as, raw material is discontinued or is declared hazardous to public health or cause rising to civil commotion, epidemics, wide-spread strikes and 21 days' notice of such eventualities is given by purchaser to the seller, the seller without any right to enforce the contract, will agree to the fore-close the performance of balance portion of this contract and in that event no claim for damages or loss will be lodged against the purchaser.
- 22.** As on the date of submission of bid against this tender, bidder should not be in the list of ineligible/ blacklisted/ banned/ debarred entity by SPMCIL/ BRBNMPL/ BNPMIPL/any Government Agency for participating in its tenders.
- 23.** Bidder may visit BNPMIPL, before submitting the offer after taking due permission for visiting to understand the requirements.
- 24.** Counter conditions (if any), will be subject to review and acceptance of BNPM. In case of non-acceptance of counter conditions by BNPM, bid shall be liable to be rejected/ignored.
- 25.** Bidders are advised to write the page number on each page of the Technical Bid documents submitted.
- 26.** The BNPMIPL reserves the right to accept the offer by individual items and reject any or all tenders without assigning any reason thereof and does not bind itself to accept lowest quotations.

27. Service Delivery:

It is responsibility of the successful bidder to arrange manpower services at BNPM, Mysore accordingly. The necessary transportation arrangement for manpower should be provided by the contractor.

If the service conditions as per the Contract are not met, the Contractor will be blacklisted and will not be considered for any future proposals.

28. Labour and Labour Laws

The successful bidder shall comply at its own cost with all prevailing statutory provisions as laid down & as applicable under various Labour Laws like- Minimum Wages Act, VDA, Provident Fund & Misc. Provisions Act, ESI,(contractor should have valid PF, ESI Registration) Bonus Act, Gratuity Act, Contract Labour Act (Regulation & Abolition), Workmen Compensation Act , Factories Act, Bonus Act , Industrial Dispute Act, Payment of



SECTION II: TERMS AND CONDITIONS OF TENDER

wages Act and all other applicable statute as applicable & amended from time to time. In case of violation of such statutory provisions under the labour law by the agency, there will not be any liability on BNPM and the contract will be liable for termination.

The successful bidder will have to obtain the valid licence (as & if applicable) under the Contract Labour (Regulation & Abolition) Act – 1970 with Contract Labour (R&A) Rules – 1971 from the appropriate authority and will have to submit the certified Xerox copy of the same to the BNPM. They have to abide by the rules made thereunder the Act.

The successful bidder has to meet and ensure all statutory liabilities such as PF, ESI, Retrenchment benefit, Leave Encashment etc. towards his workers. In addition to above, the successful bidder has to pay the amount, if any, required to be paid to these labourers as and when ordered by Labour Authorities / Court pertaining to the tenure of this contract.

29. Model Rules for Labour Welfare

The Successful bidder shall at his own expenses comply with Model rules for Labour Welfare as appended to those conditions or rules framed by the Government from time to time for the protection of health and for making sanitary arrangements for worker employed directly or indirectly on the works. In case the successful bidder fails to make arrangements as aforesaid the Purchaser shall be entitled to do so and recover the cost thereof from the successful bidder.

30. Insurance

The successful bidder shall provide ESIC/ Employee Compensation Insurance (covering the required height at which the work is to be carried out)/ Group insurance policy (as applicable) under which the person deputed will be covered, this should be to the satisfaction of the Owner as provided hereunder.

- a) The aforesaid insurance policy/policies shall provide that they shall not be cancelled till the Purchaser has agreed to their cancellation.
- b) The successful bidder shall satisfy to the Purchaser from time to time that he has taken out all insurance policies referred to above and has paid the necessary premium for keeping the policies alive till the expiry of the defects liability period.
- c) The successful bidder shall ensure that similar insurance policies are taken out by his sub-contractor (if any) and shall be responsible for any claims or losses to the Purchaser resulting from their failure to obtain adequate insurance protections in connection thereof. The contractor shall produce or cause to be produced by his sub-contractor (if any) as the case may be, the relevant policy or policies and premium receipts as and when required by the Purchaser.
- d) The deployed personnel by successful bidder at BNPM, Mysore must be covered for ESI/Insurance.

31. Rights of Rejection: BNPMIPL reserves the right to reject any or all the applied bids without assigning any reason whatsoever. The enquiry can be rejected on national security grounds.



SECTION II: TERMS AND CONDITIONS OF TENDER

- 32. Preference for Micro and Small Enterprises (*MSEs):** Public procurement policy for Micro and Small Enterprises (MSEs) order, 2012 as notified by Govt of India (GOI) along with its amendments as available in www.msme.gov.in shall be applicable to this tender.
- 33.** I/we engage to supply the material(s) to your engineering store, BNPMIPL and comply the following:
- a) Tender schedule and technical specification indicated.
 - b) Item/tender specific conditions for this tender.
 - c) Terms and conditions enclosed.
 - d) General conditions of contract signed by me at the time of supplier registration (for registered suppliers/ enclosed).
 - e) I/we confirm that set off for the GST, etc. Paid on the inputs have been taken into consideration in the above quoted price and further agree to pass on such additional duties as sets offs as may become available in future under GST, etc.
 - f) This offer is valid for 90 (Ninety) days from the date of opening of the tender.
 - g) That as on the date of submission of bid against this tender we are not in the list of ineligible/ blacklisted/ banned/ debarred entity by SPMCIL/ BRBNMPL/ BNPMIPL/any Government Agency, for participating in its tenders. (Annexure-B enclosed)
 - h) That the rates quoted are not higher than the rates quoted for same item to BNPMIPL/BRBNMPL/SPMCIL and any other Government/ Undertakings.

Signature & Seal Place & Date:		Name of Authorized Signatory:	
Address:		Tel. No./Fax. No./Mobile No. Email Id:	



SECTION III: TECHNICAL SPECIFICATIONS

S. No	Item description	Scope of work
1	REPLACEMENT OF VACUUM SEPERATOR TANK at BNPM, Mysore	<p><u>Contractor Scope:</u></p> <ul style="list-style-type: none">• Dismantling of old vacuum separator tank after removal of all inter connecting ducts.• Removal of old vacuum separator from position.• Shifting and erection of new vacuum separator to position.• Reconnection of removed ducts to new vacuum separator.• Necessary arrangements like monorail, chain blocks, skid rollers, slings, etc required for removal of old vacuum separator tank.• All required tool and tackles would be arranged by vendor.• Approximate weight of separator tank = 1 Metric Ton. <p><u>BNPM Scope:</u></p> <ul style="list-style-type: none">• All fasteners for fixing of damaged vacuum separator would be provided by BNPM.• Wall Cut outs in both lines would be in the scope of BNPM.• EOT may be provided for transportation (within the proximity of EOT cranes) of separator tanks.

Note:

1. Bidder has to visit the site before participating in tender to understand the arrangements required.
2. Bidder has to make their own arrangements for visiting BNPM site.

(To be signed & stamped and submitted along with Techno-commercial Bid Part –I)



SECTION III: TECHNICAL SPECIFICATIONS

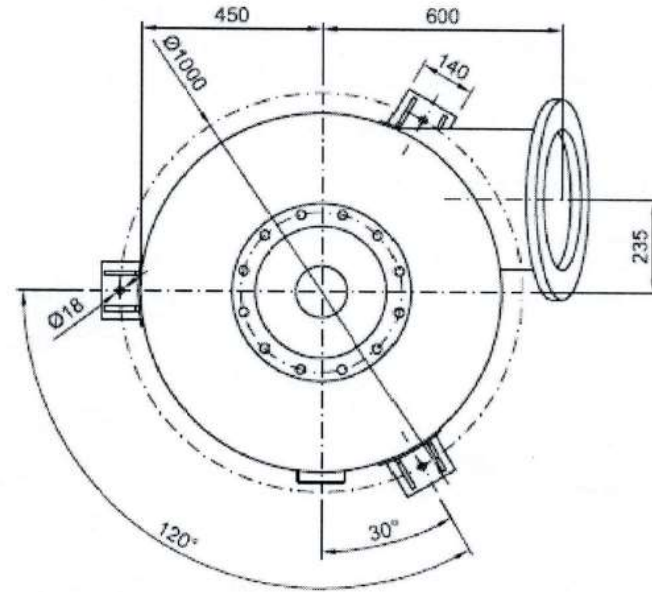
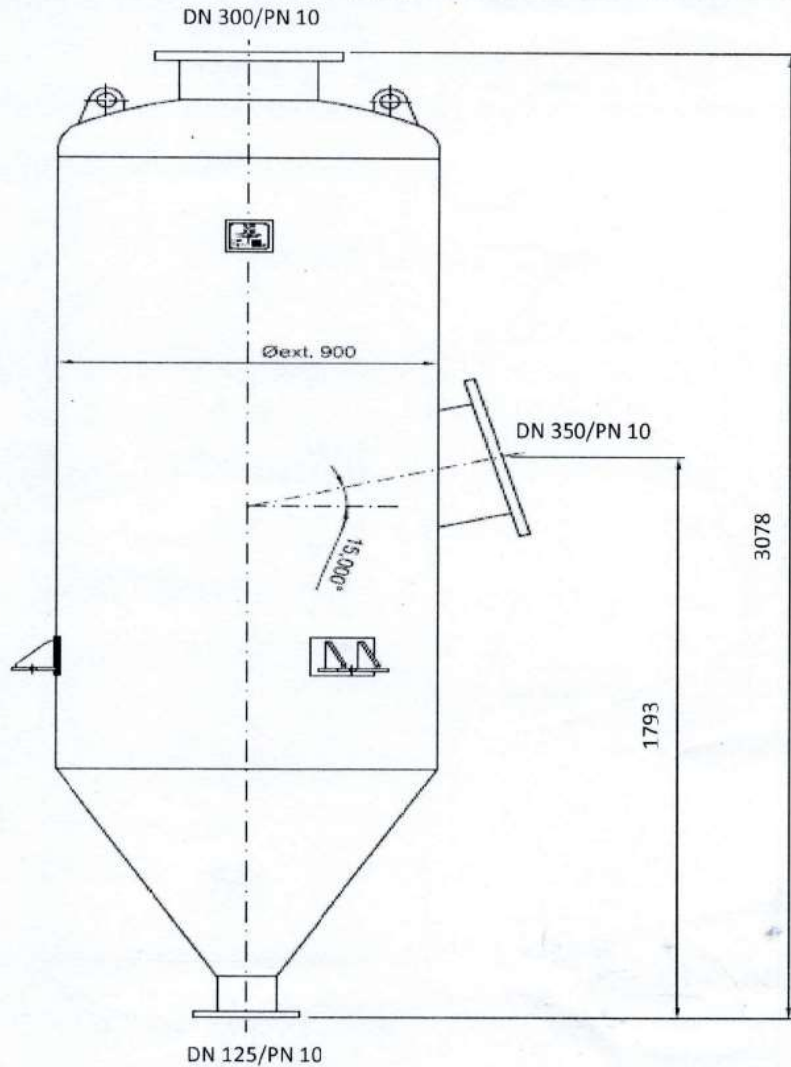

All Dimensions are in mm
Plate Thickness is 06 mm

BANK NOTE PAPER MILL INDIA PRIVATE LIMITED MYSORE-570003			
	SIGNATURE	DATE	Vacuum Separator tank for Vacuum fan no 04
PREPARED BY	<i>[Signature]</i>	25/06/24	
CHECKED BY	<i>[Signature]</i>	25-6-24	MOC : SS 316 L
APPROVED BY	<i>[Signature]</i>	25/06/24	DRG.NO:BNPM/PM/314/2024-25



SECTION IV: QUALITY CONTROL REQUIREMENTS & COMPLIANCE STATEMENT

1. **Quality:** Quality is essence of this tender. The bidder shall supply the material as per the specifications mentioned in Technical & Material Specifications. The material supplied will be inspected at our factory. Quantity as ascertained on receipt of above material at our site will be treated as quantity supplied wherever the package/materials are received intact.
2. **Rejection:** Materials not meeting our specification will be rejected outright and the rejected material shall be taken back within 7 days at the cost and risk of the supplier and replacement should be made within 15 days from the date of intimation. No payment shall be made for rejected item.

A) Technical Compliance Statement:

S. No	Item Description	Whether agreed by the bidder	Deviation if any
1	REPLACEMENT OF VACUUM SEPERATOR TANK at BNPM, Mysore (as per scope of work mentioned in Section III)	Yes Agreed	

B) Commercial Compliance Statement

Sl. No.	Features	Requirements of BNPMIPL, Terms & conditions	Whether Agreed by the firm	Deviation, if any
1	Payment Terms	As mentioned in Sl. No. 3 of Section II	Yes agreed	
2	Work Schedule	As mentioned in Sl. No. 4 of Section II	Yes agreed	
3	Contract Period Validity	As mentioned in Sl. No. 5 of Section II	Yes agreed	
4	Liquidated Damages	As mentioned in Sl.No.6 of Section II	Yes agreed	
5	Risk Purchase	As mentioned in Sl. No.17 of Section II	Yes agreed	
6	No. of pages	Total number of pages in Technical Bid		



SECTION V - DECLARATIONS

ANNEXURE -A

e-Tender No: BNPM/OTE/198/2024-25 dated 17.07.2024

Any bidder from a country which shares a land border with India will be eligible to bid in the tender only if the bidder is registered with the Competent Authority (The Registered Committee constituted by the Department for Promotion of Industry and Internal Trade)

- I) Bidder means any person or firm or company, including any member of a consortium or joint venture (that is an association of several persons, or firms, or companies), every artificial judicial person not falling in any of the descriptions of bidders stated hereinbefore, including any agency branch or office controlled by such person participating in a procurement process.
- II) "Bidder from a country which shares a land border with India" for the purpose of this order means:-
- a) An entity incorporated, established or registered in such a country; or
 - b) A subsidiary controlled through entities incorporated, established or registered in such a country, or
 - c) An entity substantially controlled through entities incorporated, established or registered in such a country, or
 - d) An entity whose beneficial owner is situated in such a country; or
 - e) An India (or other) agent of such an entity; or
 - f) A natural person who is a citizen of such a country; or
 - g) A consortium or joint venture where any member of the consortium or joint venture falls under any of the above.
- III) The beneficial owner for the purpose of (iii) above will be as under :-
- 1) In case of a company or limited liability partnership, the beneficial owner is the natural person (s), who, whether acting alone or together, or through one or more judicial person, has a controlling ownership interest or who exercise control through other means.

Further explanation:

- a) "Continuing ownership interest" means ownership of or entitlement to more than twenty five per cent of shares or capital or profits of the company;
 - b) "Control" shall include the right to appoint majority of the director or to control the management or policy decision including by virtue of their shareholding or management rights or shareholder agreements or voting agreements;
- 2) In case of partnership firm, the beneficial owner is the natural person(s) who, whether acting alone or together, or through one or more judicial person, has ownership of entitlement to more than fifteen percent of capital or profits of the partnership;
- 3) In case of an unincorporated association or body of individuals, the beneficial owner is the natural person(s), who , whether acting alone or together, or through one or more judicial



SECTION V – DECLARATIONS

person, has ownership of or entitlement to more than fifteen percent of the property or capital or profits of such association or body of individuals;

- 4) Where no natural person is identified under (1) or (2) or (3) above, the beneficial owner is the relevant natural person who holds the position of senior managing official;
- 5) In case of a trust, the identification of beneficial owners(s) shall include identification of the author of the trust, the trustee, the beneficiaries with fifteen percent or more interest in the trust and any other natural person exercising ultimate effective control over the trust through a chain of control or ownership

IV) An agent is a person employed to do any act for any another, or to represent another in dealings with tired person.

V) The successful bidder shall not be allowed to sub contract works to any contractor from a country which shares a land border with India unless such contractor is registered with the Competent Authority.

vi) A bidder is permitted to procure raw material, components, sub-assemblies etc. from the vendors from countries which shares a land border with India. Such vendors will not be required to be registered with the competent authority, as it is not regarded as sub-contracting.

vii) However, in case a bidder has proposed to supply finished goods procured directly/indirectly from the vendors from the countries sharing land border with India, such vendor will be required to be registered with the competent authority.

VII) The registration shall be valid at the time of submission of bid and at the time of acceptance of bid.

Bidder to furnish stipulated documents is support of fulfilment of qualifying criteria. Non-submission or incomplete submission of documents may lead to rejection of offer.

All experience, past performance and capacity/ capability related/ data should be certified by the authorized signatory of the bidder firm. The credentials regarding experience and past performance to the extent required as per eligibility criteria submitted by bidder may be verified from the parties for whom work has been done.

We confirm that, we are competent and legally authorized to submit the tender and / or to enter into legally binding contract.

We (Name of the company) have submitted the required documents in support of the eligibility criteria mentioned above.

Authorized Signature with stamp & date



SECTION V – DECLARATIONS

ANNEXURE -A1

Tender No: BNPM/OTE/198/2024-25 dated 17.07.2024

(To be submitted on Company letterhead)

DECLARATION

I have read the clause regarding restrictions on procurement from a bidder of a country which shares a land border with India. I hereby certify that, M/s is not from such a country or, if from such a country, has been registered with the Competent Authority. I hereby certify that M/s fulfills all requirements in this regard and is eligible to be considered.” (Where applicable, evidence of valid registration by the Competent Authority shall be attached.)

I, the undersigned, declare that the item originate in (Name of the country).

Signature _____

Name-----

Designation-----

Date-----

Stamp of the Organization-----



SECTION V – DECLARATIONS

ANNEXURE –B

e-Tender No: BNPM/OTE/198/2024-25 dated 17.07.2024

(To be submitted on the letterhead)

DECLARATION

I) We do hereby declare that,

1. As on the date of submission of bid against this tender we are not in the list of ineligible/ blacklisted/ banned/ debarred entity by SPMCIL/ BRBNMPL/ BNPMIPL/any Government Agency, for participating in its tenders.

Further, we agree, in case we get blacklisted/ banned/ debarred by SPMCIL/ BRBNMPL/ BNPMIPL/any Government Agency, any time prior to finalization of tender/ contract, our bid shall not be considered for further evaluation/ award of order.

2. The director/proprietor of the bidding firm are not closely related to BNPMIPL.

In case, at any time the information furnished is found to be false, you may disqualify/ debar me/ us as deemed fit.

Signature _____

Name-----

Designation-----

Date-----

Stamp of the Organization-----



SECTION V - DECLARATIONS

ANNEXURE C

e-Tender No: BNPM/OTE/198/2024-25 dated 17.07.2024

(To be submitted on the letterhead)

We, the undersigned, declare that we will automatically be suspended from being eligible for bidding in any tender with Bank Paper Mill India Private Limited, Mysore for the period of 12 months, if we are withdrawing our Bid during the period of bid validity (or) fail / refuse to furnish the performance security / execute the contract, if awarded.

Signature _____

Name-----

Designation-----

Date-----

Stamp of the Organization-----



SECTION V: PRICE BID FORMAT (TO BE FILLED ONLINE THROUGH E-TENDER PORTAL)

Dear Sir,

Sub: PRICE BID FOR REPLACEMENT OF VACUUM SEPERATOR TANK AT BNPM, MYSORE

Ref: Tender No: BNPM/OTE/198/2024-25 dated 17.07.2024

We have received and understood the above tender enquiry and are pleased to submit our price bid as under:

Sch. No.	Description	UOM	Ten tati ve Qty	HSN/ SAC	Basic Unit price (INR)	P&F, Freight & Transit Insurance & any other charges(if any) per unit (INR)	Unit Price (incl. of P&F, Freight, Transit Insurance & any other charges (if any) excl. of GST) (INR)	GST (%)	GST on Unit Price (INR)	Total Unit Price (incl. of GST) (INR)	Less: Input Credit (GST) (INR)	Effective Unit Price (net of input tax credit) (F.O.R Mysore) (INR)	Total Effective price (net of input tax credit) (F.O.R Mysore) (INR)
			A		B	C	D=B+C	E	F=D*E	G=D+F	H=F	I=G-H	J=I*A
1.	Replacement of Vacuum Separator Tank at BNPM, Mysore as per scope of work mentioned in Section III	No's	2										
Total effective price (net of input tax credit) for Replacement of vacuum separator tank with loading, P&F, Transit Insurance and any other charges (F.O.R – BNPM, Mysore site) in Figures (INR)													
Total effective price (net of input tax credit) for Repair of shaft bearing seating area with freight, P&F, Transit Insurance and any other charges (F.O.R – BNPM, Mysore site) (in words) (INR)													

Note: Prices quoted above shall be FOR BNPM, Mysore site basis inclusive of GST, Packing & Forwarding charges, freight, transit insurance and all other charges if applicable less input GST. Evaluation shall be carried out based on overall lowest effective price.

