

SECTION IV – GENERAL CONDITIONS OF CONTRACT

that the goods have been inspected after the contractual delivery period will not have the effect of keeping the contract alive and this will be without any prejudice to the legal rights and remedies available to BNPM under the terms & conditions of the contract.

9.7 BNPM's contractual right to inspect, test and, if necessary, reject the goods after the goods' arrival at the final destination shall have no bearing of the fact that the goods have previously been inspected and cleared by BNPM's inspector during pre-despatch inspection mentioned above.

9.8 Goods accepted by BNPM and/or its inspector at initial inspection and in final inspection in terms of the contract shall in no way dilute BNPM's right to reject the same later, if found deficient in terms of the warranty clause of the contract, as incorporated under GCC Clause 16.

10. Terms of Delivery

10.1 Goods shall be delivered by the supplier in accordance with the terms of delivery specified in the contract.

11. Transportation of Goods

11.1 The supplier shall not arrange part-shipments and/ or transshipment without the express/prior written consent of BNPM.

11.2 Instructions for transportation of domestic goods including goods already imported by the supplier under its own arrangement:

In case no instruction is provided in this regard in the specification, the supplier shall arrange transportation of the ordered goods as per its own procedure.

11.3 Shipping Arrangement for Foreign Contracts: In the case of FOB/FAS contracts, shipping arrangements shall be made by the Ministry of Shipping & Transport (Chartering Wing), New Delhi, INDIA, in accordance with details given in Volume I. The Contractor shall give adequate notice to the Forwarding Agents/Nominees about the readiness of the cargo from time to time and at least six weeks' notice in advance of the required position for finalising the shipping arrangements. In the case of C&F contracts, the Contractor shall arrange shipment in accordance with the requirements of the Ministry of Shipping & Transport, New Delhi, INDIA, indicated in the Volume I (as applicable).

12. Insurance

12.1 Unless otherwise instructed in the SCC, the supplier shall make arrangements for insuring the goods against loss or damage incidental to manufacture or acquisition, transportation, storage and delivery in the following manner:

12.2 In case of supply of domestic goods on CIF destination basis, the supplier shall be responsible till the entire stores contracted for arrives in good condition at the destination. The transit risk in this respect shall be covered by the Supplier by getting the stores duly insured. The insurance cover shall be obtained by the Supplier in its own name and not in the name of BNPM or its Consignee.

12.3 In the case of FOB and C&F offers for import of Goods, insurance shall be arranged by the Purchaser. However, the supplier must give sufficient notice to the Purchaser prior to the date of shipment, so that the Insurance Cover for the shipment can be activated. The Supplier must co-ordinate so as to ensure that the Shipment sails only with Insurance cover in place.

12.4 In case of Import of Goods, even in case where the insurance is paid by the Purchaser, and loss or damage shall be made good by the Contractor free of cost, without waiting for the settlement of insurance claim. The payment after settlement of insurance claim shall be reimbursed by the Purchaser to the Contractor. Contractor shall be entirely responsible to make good loss/damage without waiting for settlement of insurance claim so that machine is commissioned within the time specified in the contract.

13. Spare parts

13.1 If specified in the List of Requirements and in the resultant contract, the supplier shall supply any or all of the following materials, Information etc. pertaining to spare parts manufactured and/or supplied by the supplier:

a) The spare parts as selected by BNPM to be purchased from the supplier, subject to the condition that such purchase of the spare parts shall not relieve the supplier of any contractual obligation including warranty obligations; and

b) In case the production of the spare parts is discontinued:

i) Sufficient advance notice shall be given to BNPM before such dis-continuation to provide adequate time to BNPM to purchase the required spare parts etc. &

ii) Immediately following such dis-continuation, the supplier shall provide BNPM designs, drawings, lay-outs & specifications of spare parts as required by BNPM free of cost.

13.2 Supplier shall carry sufficient inventories to assure ex-stock supply of consumable spares for the goods so that the same are supplied to BNPM promptly on receipt of order from BNPM.

14. Incidental services

14.1 Subject to the stipulation, if any, in the SCC under volume I and the Technical Specifications, the supplier shall be required to perform any or all of the following services.

a) Providing required jigs and tools for assembly, start-up and maintenance of the goods

b) Supplying required number of operation & maintenance manual for the goods

c) Installation and commissioning of the goods

d) Training of BNPM's operators for operating and maintaining the goods

e) Providing after sales service during the tenure of the contract

f) Providing maintenance service after expiry of the warranty period of the goods if so incorporated in the contract

14.2 Prices to be paid to the supplier by BNPM for any of the required incidental services, if not already included in the contract price during the placement of the contract, shall be settled and decided in advance by BNPM and the supplier. However, such prices shall not exceed the contemporary rates charged by the supplier to other customers for similar services.

15. Distribution of Despatch Documents for Clearance/ Receipt of Goods

15.1 The supplier shall send all the relevant despatch documents well in time to BNPM to enable BNPM to clear or receive (as the case may be) the goods in terms of the contract. Unless

SECTION IV – GENERAL CONDITIONS OF CONTRACT

otherwise specified in the SCC, the usual documents involved and the practice to be followed in general for this purpose are as follows:

15.2 For Domestic Goods, including goods already imported by the supplier under its own arrangement Within 24 hours of despatch, the supplier shall notify BNPM, consignee, and others concerned if mentioned in the contract, the complete details of despatch and also supply the following documents to them by registered post/speed post (or as instructed in the contract):

- a) Supplier's Invoice indicating, inter alia description and specification of the goods, quantity, unit price, total value
- b) Packing list
- c) Insurance certificate
- d) Railway receipt/Consignment note
- e) Manufacturer's guarantee certificate and in-house inspection certificate
- f) Inspection certificate issued by BNPM's inspector, if applicable
- g) Expected date of arrival of goods at destination and
- h) Any other document(s), as and if specifically mentioned in the contract.

15.3 For Imported Goods, within 3 days of dispatch, the supplier shall notify BNPM, consignee and others concerned if mentioned in the contract, the complete details of dispatch and also supply the following documents to them by Courier (or as instructed in the Contract), besides advance intimation by Fax/ email:

- a) Clean on Board Airway Bill/Bill of Lading (B/L)
- b) Original Invoice
- c) Packing List
- d) Certificate of Origin from Seller's Chamber of Commerce
- e) Certificate of Quality and current manufacture from OEM
- f) Dangerous Cargo Certificate, if any.
- g) Insurance Policy of 110% if CIF contract.
- h) Performance Bond / Warranty Certificate

16. Warranty

16.1 The supplier warrants that the goods supplied under the contract is new, unused and incorporates all recent improvements in design and materials unless prescribed otherwise by BNPM in the contract. The supplier further warrants that the goods supplied under the contract shall have no defect arising from design, materials (except when the design adopted and / or the material used are as per BNPM's specifications) or workmanship or from any act or omission of the supplier, that may develop under normal use of the supplied goods under the conditions prevailing in India.

16.2 This warranty shall remain valid for twelve months after the goods or any portion thereof as the case may be, have been delivered to the final destination and installed and commissioned at the final destination and accepted by BNPM in terms of the contract or for fifteen months from the date of despatch of the last item to be supplied under the contract from the supplier's premises for domestic goods (including goods already imported by the supplier under its own

arrangement) or for eighteen months from the date of shipment from the port of loading in the source country for imported goods offered from abroad, whichever is earlier, unless specified otherwise in the specifications.

16.3 In case of any claim arising out of this warranty, BNPM shall promptly notify the same in writing to the supplier.

16.4 Upon receipt of such notice, the supplier shall, within a reasonable span of time (or within the period, if specified in the SCC), repair or replace the defective goods or parts thereof, free of cost, at the ultimate destination. The supplier shall take over the replaced parts/goods after providing their replacements and no claim, whatsoever shall lie on BNPM for such replaced parts/goods thereafter.

16.5 In the event of any rectification of a defect or replacement of any defective goods during the warranty period, the warranty for the rectified/ replaced goods shall be extended to a further period of twelve months from the date such rectified/ replaced goods starts functioning to the satisfaction of BNPM.

16.6 If the supplier, having been notified, fails to rectify/replace the defect(s) within a reasonable period (or within the period, if specified in the SCC), BNPM may proceed to take such remedial action(s) as deemed fit by BNPM, at the risk and expense of the supplier and without prejudice to other contractual rights and remedies, which BNPM may have against the supplier.

17. Assignment

17.1 The Supplier shall not assign, either in whole or in part, its contractual duties, responsibilities and obligations to perform the contract, except with BNPM's prior written permission.

18. Sub Contracts

18.1 The Supplier shall notify BNPM in writing of all sub contracts awarded under the contract if not already specified in its tender. Such notification, in its original tender or later, shall not relieve the Supplier from any of its liability or obligation under the terms and conditions of the contract.

18.2 Sub contract shall be only for bought out items and sub-assemblies.

18.3 Sub contracts shall also comply with the provisions of GCC Clause 5 "Country of Origin").

19. Modification of contract

19.1 Once a contract has been concluded, the terms and conditions thereof shall generally not vary. However if necessary, BNPM may, by a written order given to the supplier at any time during the currency of the contract, amend the contract by making alterations and modifications within the general scope of contract in any one or more of the following:

- a) Specifications, drawings, designs etc. where goods to be supplied under the contract are to be specially manufactured for BNPM,
- b) Mode of packing
- c) Incidental services to be provided by the supplier
- d) Mode of dispatch
- e) Place of delivery, and
- f) Any other area(s) of the contract as felt necessary by BNPM depending on the merits of the case.

SECTION IV – GENERAL CONDITIONS OF CONTRACT

- 19.2 In the event of any such modification/alteration causing increase or decrease in the cost of goods and services to be supplied and provided, or in the time required by the supplier to perform any obligation under the contract, an equitable adjustment shall be made in the contract price and/or contract delivery schedule, as the case may be, and the contract amended accordingly. If the Supplier doesn't agree to the adjustment made by BNPM, the supplier shall convey its views to BNPM within twenty-one days from the date of the supplier's receipt of BNPM's amendment/modification of the contract.
- 19.3 Option Clause: By a suitable provision in the SCC, the Purchaser may reserve the right to increase the ordered quantity by 25% at any time, till final delivery date of the contract, by giving reasonable notice even though the quantity ordered initially has been supplied in full before the last date of Delivery Period.
- 20. Prices**
- 20.1 Prices to be charged by the supplier for supply of goods and provision of services in terms of the contract shall not vary from the corresponding prices quoted by the supplier in its tender or during negotiations, if any, and incorporated in the contract except for any price adjustment authorized in the SCC.
- 21. Taxes and Duties**
- 21.1 Supplier shall be entirely responsible for all taxes, duties, fees, levies etc. incurred until delivery of the contracted goods to BNPM.
- 21.2 Further instruction, if any, shall be as provided in the SCC.
- 22. Terms and Mode of Payment:** Unless specified otherwise in SCC, the terms of payments would be as follows:
- 22.1 Unless otherwise specified in SCC, usual payment term is 100% on receipt and acceptance of goods by the Purchaser and on production of all required documents by the supplier.
- 22.2 For Domestic Goods: Unless otherwise specified in the SCC, payments to suppliers are usually made by account payee cheque or through ECS only.
- 22.2.1 Where the terms of delivery is FOR dispatching Station, the payment terms depending on the value and nature of the goods, mode of transportation etc. maybe - 60% to 90% (as specified in SIT) on proof of dispatch and other related documents and balance on receipt at site and acceptance by the consignee.
- 22.2.2 Where the terms of delivery is CIF destination/delivery at site/FOR destination, usual payment term is 100% on receipt and acceptance of goods by the consignee and on production of all required documents by the supplier.
- 22.2.3 Where goods to be supplied also need installation and commissioning by the supplier, the payment terms are generally as under:
- a) For a contract with terms of delivery as F.O.R. dispatching station
- i) 60% on proof of despatch along with the other specified documents.
- ii) 30% on receipt of the goods at site by the consignee and balance
- iii) 10% on successful installation and commissioning and acceptance by the Purchaser.
- b) For a contract with terms of delivery as CIF destination/ Delivery at site/FOR destination
- i) 90% on receipt and acceptance of goods by the consignee at destination and on production of all required documents by the supplier
- ii) 10% on successful installation and commissioning and acceptance by the consignee.
- 22.3 For Imported Good: Unless otherwise specified in SCC, payments are made through an irrevocable Letter of Credit (LC).
- a) Cases where Installation, Erection and Commissioning (if applicable) are not the responsibility of the Supplier- 100 % net FOB/FAS price is to be paid against invoice, shipping documents, inspection certificate (where applicable), manufacturers' test certificate, etc.
- b) Cases where Installation, Erection and Commissioning are the responsibility of the Supplier-80%- 90% net FOB/FAS price (as specified in the SCC) will be paid against invoice, inspection certificate (where applicable), shipping documents etc. and balance within 21-30 days of successful installation and commissioning at the consignee's premises and acceptance by the consignee.
- c) Payment of Agency Commission against FOB/FAS Contract - Entire 100% agency commission is generally paid in Indian Rupees; after all other payments have been made to the supplier in terms of the contract.
- 22.4 Unless specified otherwise in the SCC, the following general conditions will apply for payment to the supplier.
- 22.5 The payment shall be made in the currency/ currencies authorized in the contract.
- 22.6 The supplier shall send its claim for payment in writing as per Section XIX - " Proforma for Bill for Payments", when contractually due, along with relevant documents etc., duly signed with date, as specified in sec and in a manner as also specified therein.
- While claiming payment, the supplier is also to certify in the bill that the payment being claimed is strictly in terms of the contract and all the obligations on the part of the supplier for claiming that payment has been fulfilled as required under the contract. The supply should take place in sequence of erection and installation for claiming payment.
- 22.7 The important documents which the supplier is to furnish while claiming payment are:
- a) Original Invoice
- b) Packing List
- c) Certificate of country of origin of the goods from seller's Chamber of Commerce.
- d) Certificate of pre-dispatch inspection by BNPM's representative/ nominee
- e) Manufacturer's test certificate
- f) Performance/ Warrantee Bond
- g) Certificate of Insurance
- h) Bill of landing/ Airway bill/ Rail receipt or any other dispatch document, issued by a government agency (like postal department) or an agency duly authorized by the concerned ministry/department

SECTION IV – GENERAL CONDITIONS OF CONTRACT

- i) Consignee's Certificate confirming receipt and acceptance of goods
- j) Dangerous Cargo Certificate, if any, in case of Imported Goods.
- k) Any other document specified.

22.8 While claiming reimbursement of duties, taxes etc. (like sales tax, excise duty, custom duty) from BNPM, as and if permitted under the contract, the supplier shall also certify that, in case it gets any refund out of such taxes and duties from the concerned authorities at a later date, it (the supplier) shall refund to BNPM, BNPM's share out of such refund received by the supplier. The supplier shall also refund the applicable amount to BNPM immediately on receiving the same from the concerned authorities.

22.9 In case where the supplier is not in a position to submit its bill for the balance payment for want of receipted copies of Inspection Note from the consignee and the consignee has not complained about the non-receipt, shortage, or defects in the supplies made, balance amount will be paid by the paying authority without consignee's receipt certificate after three months from the date of the preceding part payment for the goods in question, subject to the following conditions:

- a) The supplier will make good any defect or deficiency that the consignee (s) may report within six months from the date of despatch of goods.
- b) Delay in supplies, if any, has been regularized.
- c) The contract price where it is subject to variation has been finalized.
- d) The supplier furnishes the following undertakings:

"I/ We, ----- certify that I/ We have not received back the Inspection Note duly receipted by the consignee or any communication from BNPM or the consignee about non-receipt, shortage or defects in the goods supplied. I/ We agree to make good any defect or deficiency that the consignee may report within three months from the date of receipt of this balance payment".

23. Delay in the supplier's performance

23.1 The time for and the date specified in the contract or as extended for the delivery of the stores shall be deemed to be the essence of the contract and the supplier shall deliver the goods and perform the services under the contract within the time schedule specified by BNPM in the List of Requirements and as incorporated in the contract.

23.2 Subject to the provision under GCC clause 28, any delay attributable to the supplier in maintaining its contractual obligations towards delivery of goods and performance of services shall render the supplier liable to any or all of the following sanctions besides any administrative action:

- a) Imposition of liquidated damages
- b) Forfeiture of its performance security and
- c) Termination of the contract for default.

23.3 If at any time during the currency of the contract, the supplier encounters conditions hindering timely delivery of the goods and performance of services, the supplier shall promptly inform BNPM in writing about the same and its likely duration and make a request to BNPM for extension of the delivery schedule accordingly. On receiving the supplier's communication, BNPM shall examine the situation as soon as possible and, at its discretion, may agree to extend the

delivery schedule, with or without liquidated damages for completion of supplier's contractual obligations by issuing an amendment to the contract.

23.4 When the period of delivery is extended due to delay for reasons attributable to the supplier, the amendment letter extending the delivery period shall, inter alia contain the following conditions:

- a) BNPM shall recover from the supplier, under the provisions of the clause 24 of the General Conditions of Contract, liquidated damages on the goods and services, which the Supplier has failed to deliver within the delivery period stipulated in the contract.
- b) That no increase in price on account of any ground whatsoever, including any stipulation in the contract for increase in price on any other ground and, also including statutory increase in or fresh imposition of customs duty, excise duty, sales tax or on account of any other tax or duty which may be levied in respect of the goods and services specified in the contract, which takes place after the date of delivery stipulated in the contract shall be admissible on the said goods and services delivered and performed after the date of the delivery stipulated in the contract.
- c) But nevertheless, BNPM shall be entitled to the benefit of any decrease in price on account of reduction in or remission of customs duty, excise duty, sales tax or any other duty or tax or levy or on account of any other grounds, which takes place after the expiry of the date of delivery stipulated in the contract.

23.5 The supplier shall not despatch the goods after expiry of the delivery period. The supplier is required to apply to BNPM for extension of delivery period and obtain the same before despatch. In case the supplier despatches the goods without obtaining an extension, it would be doing so at its own risk and no claim for payment for such supply and/or any other expense related to such supply shall lie against BNPM.

24. Liquidated damages

24.1 Subject to GCC clause 28, if the supplier fails to deliver any or all of the goods or fails to perform the services within the time frame(s) incorporated in the contract, BNPM shall, without prejudice to other rights and remedies available to BNPM under the contract, deduct from the contract price, as liquidated damages, a sum equivalent to the 0.5% (Half) percent (or any other percentage if prescribed in the SCC) of the delivered price of the delayed goods and/ or services for each week of delay or part thereof until actual delivery or performance, subject to a maximum deduction of the 10% (or any other percentage if prescribed in the SCC) of the delayed goods' or services' contract price(s). During the above-mentioned delayed period of supply and/ or performance, the conditions incorporated under GCC sub-clause 23.4 above shall also apply.

24.2 Liquidated Damage for not meeting performance guarantee shall be assessed and recovered from the Supplier, if applicable. The quantum of Liquidated damages shall be as specified in SCC.

24.3 If the equipment/system while testing, in accordance with the performance requirement of the Contract, fails to meet those performance parameters, the damages suffered by the purchaser may not be quantified in terms of money with any reasonable certainty. Therefore, any Liquidated damage set forth in the Contract shall represent a reasonable determination of the amount of damage that the Purchaser will suffer, and shall not be considered as penalties. The

SECTION IV – GENERAL CONDITIONS OF CONTRACT

Supplier thereby waives any defence to Purchaser's recovery of such Liquidated Damages on the plea that actual damages are ascertainable or that such Liquidated damages do not represent a reasonable determination of damages suffered by Purchaser or are penalties.

24.4 If the LD exceeds the specified limit, the Purchaser shall reserve the right to cancel/terminate the Contract as per clause 26 of GCC.

25. Custody and Return of BNPM Materials/ Equipment Documents loaned to Contractor

25.1 Whenever stores are required to be issued to the firm/contractor for fabrication or prototypes or sub-assemblies are issued for guidance in fabrication, these would be issued against appropriate Bank Guarantee as specified in SCC. In addition to the Bank Guarantee, appropriate insurance may be asked for if specified in the SCC.

25.2 In-case of failure of returning of all drawings and samples issued to the contractor in connection with the contract, besides withholding final payment, any other sanction, as deemed fit by BNPM, shall be issued against the supplier.

26. Termination for default

26.1 BNPM, without prejudice to any other contractual rights and remedies available to it (BNPM), may by written notice of default sent to the supplier, terminate the contract in whole or in part, if the supplier fails to deliver any or all of the goods or fails to perform any other contractual obligation(s) within the time period specified in the contract, or within any extension thereof granted by BNPM pursuant to GCC sub-clauses 23.3 and 23.4.

26.2 In the event of BNPM terminates the contract in whole or in part, pursuant to GCC sub- clause 26.1 above, BNPM may procure goods and/ or services similar to those cancelled, with such terms and conditions and in such manner as it deems fit at the "Risk and Cost" of the supplier and the supplier shall be liable to BNPM for the extra expenditure, if any, incurred by BNPM for arranging such procurement.

26.3 Unless otherwise instructed by BNPM, the supplier shall continue to perform the contract to the extent not terminated.

27. Termination for insolvency

If the supplier becomes bankrupt or otherwise insolvent, BNPM reserves the right to terminate the contract at any time, by serving written notice to the supplier without any compensation, whatsoever, to the supplier, subject to further condition that such termination will not prejudice or affect the rights and remedies which have accrued and I or will accrue thereafter to BNPM.

28. Force Majeure

28.1 In the event of any unforeseen event directly interfering with the supply of stores arising during the currency of the contract, such as war, hostilities, acts of the public enemy, civil commotion, sabotage, fires, floods, explosions, epidemics, quarantine restrictions, strikes, lockouts, or acts of God, the Contractor shall, within a week from the commencement thereof, notify the same in writing to the Purchaser with reasonable evidence thereof. Unless otherwise directed by BNPM in writing, the supplier shall continue to perform its obligations under the contract as far as reasonably practical, and shall seek all reasonable alternative means for performance not prevented by the Force Majeure event. If the force majeure condition(s) mentioned above be in force for a period of 90 days or more at any time, either party shall have the option to terminate the contract on expiry of 90 days of commencement of such force

majeure by giving 14 days' notice to the other party in writing. In case of such termination, no damages shall be claimed by either party against the other, save and except those which had occurred under any other clause of this contract prior to such termination.

28.2 Notwithstanding the provisions contained in GCC clauses 23, 24 and 26, the supplier shall not be liable for imposition of any such sanction so long the delay and/ or failure of the supplier in fulfilling its obligations under the contract is the result of an event of Force Majeure.

28.3 In case due to a Force Majeure event BNPM is unable to fulfil its contractual commitment and responsibility, BNPM will notify the supplier accordingly and subsequent actions taken on similar lines described in above sub-paragraphs.

29. Termination for convenience

29.1 BNPM reserves the right to terminate the contract, in whole or in part for its (BNPM's) convenience, by serving written notice on the supplier at any time during the currency of the contract. The notice shall specify that the termination is for the convenience of BNPM. The notice shall also indicate inter-alia, the extent to which the supplier's performance under the contract is terminated, and the date with effect from which such termination will become effective.

29.2 The goods and services which are complete and ready in terms of the contract for delivery and performance within thirty days after the supplier's receipt of the notice of termination shall be accepted by BNPM following the contract terms, conditions and prices. For the remaining goods and services. BNPM may decide:

- a) To get any portion of the balance completed and delivered at the contract terms, conditions and prices; and / or
- b) To cancel the remaining portion of the goods and services and compensate the supplier by paying an agreed amount for the cost incurred by the supplier towards the remaining portion of the goods and services.

30. Governing language

30.1 The contract shall be written in English language following the provision as contained in GIT clause 2. All correspondence and other documents pertaining to the contract, which the parties exchange, shall also be written accordingly in that language.

31. Notices

31.1 Notice, if any, relating to the contract given by one party to the other, shall be sent in writing or by cable or telex or facsimile and confirmed in writing. The procedure will also provide the sender of the notice, the proof of receipt of the notice by the receiver. The addresses of the parties for exchanging such notices will be the addresses as incorporated in the contract.

31.2 The effective date of a notice shall be either the date when delivered to the recipient or the effective date specifically mentioned in the notice, whichever is later.

32. Code of Ethics

BNPM as well as Bidders, Suppliers, Contractors, and Consultants under BNPM contracts shall observe the highest standard of ethics during the procurement or execution of such contracts. In pursuit of this policy, for the purposes of this provision, the terms set forth below are defined as follows:

SECTION IV – GENERAL CONDITIONS OF CONTRACT

- a) "Corrupt practice" means the offering, giving, receiving, or soliciting, directly or indirectly, of anything of value to influence the action of a public official in the procurement process or in contract execution;
- b) "Fraudulent practice" means a misrepresentation or omission of facts in order to influence a procurement process or the execution of a contract;
- c) "Collusive practice" means a scheme or arrangement between two or more Bidders, with or without the knowledge of the Purchaser, designed to establish bid prices at artificial, non-competitive levels; and
- d) "Coercive practice" means harming or threatening to harm, directly or indirectly, persons or their property, procurement process or affect the execution of a contract.
- e) A particular violation of ethics may span more than one of above mentioned unethical practices.

32.1 The following policies will be adopted in order to maintain the standards of ethics during procurement:

- a) A proposal for award will be rejected if it is determined that the Bidder recommended for award has, directly or through an agent, engaged in corrupt, fraudulent, collusive or coercive practices in competing for the Contract in question.
- b) A contract will be cancelled if it is determined at any time that BNPM representatives/officials have directly or indirectly, engaged in corrupt, fraudulent collusive or coercive practices during the procurement or the execution of that contract.
- c) In case any individual staff is found responsible, suitable disciplinary proceedings should be initiated against such staff under the applicable conduct rules. The existing provisions under the Indian law including the instructions of Central Vigilance Commission should be followed in this regard.
- d) Firms or individuals shall be banned/ blacklisted after following due process, including declaring them ineligible, either indefinitely or for a stated period of time, to be awarded a BNPM contract, if it at any time determines that they have, directly or through an agent, engaged in corrupt, fraudulent, collusive or coercive practices in competing for, or in executing, a BNPM contract.

33. Resolution of disputes

- 33.1 If dispute or difference of any kind shall arise between BNPM and the supplier in connection with or relating to the contract, the parties shall make every effort to resolve the same amicably by mutual consultations. If the parties fail to resolve their dispute or difference by such mutual consultation within twenty one days of its occurrence, then, unless otherwise provided in the SCC, either BNPM or the supplier may seek recourse to settlement of disputes through arbitration as per The Arbitration and conciliation Act 1996 as per following clause.
- 33.2 Arbitration Clause: - Any dispute or difference whatsoever arising between the Parties out of or relating to the construction, meaning, scope operation or effect of this Agreement or the validity or the breach thereof shall be settled by arbitration in accordance with the Arbitration and Conciliation Act, 1996 and under the Rules of Arbitration of the Indian Council of Arbitration and the award made in pursuance thereof shall be binding on the Parties. The Arbitral Tribunal shall consist of three Arbitrators. The venue of the Arbitration shall be Bangalore and it shall be conducted in English language.

34. Applicable Law

34.1 The contract shall be interpreted in accordance with the laws of India.

34.2 Irrespective of the place of delivery, or the place of performance or the place of Payments under the contract, the contract shall be deemed to have been made at the place from which the notification of acceptance of the tender has been issued.

34.3 The courts of the place from where the notification of acceptance has been issued- shall alone have jurisdiction to decide any dispute arising out or in respect of the contract.

35. Secrecy

35.1 The Contractor shall take all reasonable steps necessary to ensure that all persons employed in any work in connection with the contract, have full knowledge of the Official Secrets Act and any regulations framed thereunder.

35.2 Any information obtained in the course of the execution of the contract by the Contractor,; his servants or agents or any person so employed, as to any matter whatsoever, which would or might be directly or indirectly, of use to any enemy of India, must be treated secret and shall not at any time be communicated to any person.

35.3 Any breach of the aforesaid conditions shall entitle the Purchaser to cancel the contract and to purchase or authorise the purchase of the stores at the risk and cost of the Contractor, In the event of such cancellation, the stores or parts manufactured in the execution of the contract shall be taken by the Purchaser at such price as he considers fair and reasonable and the decision of the Purchaser as to such price shall be final and binding on the Contractor.

Part II: Additional General Conditions of Contract for specific Types of Tenders in addition/ modification to clauses mentioned above:

36. Disposal / Sale of Scrap by Tender - **NOT APPLICABLE**

36.1 During the currency of contract, no variation in price or rate shall be admissible.

36.2 Payment and Default

36.2.1 Payment may be made in the form of cash or Demand Draft /Pay order issued by any scheduled commercial bank and drawn in favour of the Account mentioned in the NIT.

36.2.2 No interest will be paid to the purchaser for the amounts paid or deposited with the BNPM and subsequently found refundable to the purchaser under any of the conditions of the contract.

36.2.3 If the purchaser fails to deposit sale value for a sold lot within the allowed period as per relevant clause BNPMIPL may forfeit the security deposit. Requests for an extension of this period, made by the purchaser may be considered by the BNPMIPL and may at its discretion, on the merits of the case, allow further time not excluding 50 days from the date of the contract. Interest shall be leviable on such amount at a rate 2% per annum higher than the PLR of State Bank of India, from the date of expiry of the payment date to actual date of payment (actual date of payment inclusive).

36.2.4 The lot or lots in respect of which forfeiture has been made, shall be deemed to have been abandoned by the purchaser to all intents and purposes and may be re-sold or otherwise disposed of at the discretion of the BNPMIPL without reference to the purchaser concerned and without incurring any liability on part of BNPMIPL whatsoever in respect there under.

36.2.5 In case extension is granted by BNPMIPL and due to late payment of sale amount the delivery cannot be completed by the purchaser, in accordance with the relevant clause of Special Conditions of Tender sale, then ground rent shall also be leviable as per relevant clause of Special Conditions of Tender sale.

SECTION IV – GENERAL CONDITIONS OF CONTRACT

36.2.6 On production of proof of having made payment, nominated authority shall issue a delivery order authorizing the purchaser to take delivery of the Scrap Materials.

36.3 Deliveries, Delays and Breach of Contract

36.3.1 The Title of goods or material sold shall not be deemed to have been passed to the Purchaser / Bidder until and unless the full and final payment has been made by the purchaser, in accordance with the contract to the BNPMIPL and the authorized Officer has issued the Delivery Order in favour of the purchaser. The materials sold may be removed from the premises only on production of the cash receipt for the payment and a delivery order from the Officer authorized by the BNPMIPL.

36.3.2 Unless specified otherwise in SIT, delivery period for lifting of material shall be within 60 days from the date of finalization of contract agreement.

36.3.3 The work of delivery will be supervised by Stock Holder or his authorized representative, representative of accounts Department and Security Staff duly authorized by BNPMIPL for the propose of delivery. Delivery will be allowed during working hours.

36.3.4 No delivery of or materials sold shall be given on Sundays, Gazetted holidays and other shall holidays observed by BNPMIPL. The delivery of the goods or material shall be effected from the premises concerned only during its normal working hours. In order to complete the delivery within the working hours all loading must cease half an hour before the normal closing time of the concerned premises. The decision of the BNPMIPL with regard to the working hour shall be final and binding on the purchaser. Purchaser will not be allowed to lift the Scrap Material from more than one location at a time.

36.3.5 The purchased stores will be carried away by the purchaser at his risk and no claims against the BNPMIPL will be entertained for shortage in weight which may be discovered after the materials have left the premises wherefrom delivery is taken. If required the purchaser shall provide his own bags, cases or other receptacles for the removal of the scrap.

36.3.6 The BNPMIPL shall not be responsible for any accident that may occur to purchaser's labours /servants for any reasons whatsoever. The purchaser will himself have to ensure the safety of his workers and shall be liable to pay claims, whatsoever if any. BNPMIPL will not carry any responsibility of such payments. The purchaser will be responsible to supply personal protection equipment's to his labour/servant and staff and no additional charges are admissible for the same.

36.3.7 The materials sold, shall be removed by the purchaser within the period specified in relevant clause of Special Condition of Sale.

36.3.8 If due to any default on the part of the BNPMIPL, the purchaser is unable to remove the materials sold within the specified period, the BNPMIPL may extend the period therefore and in such an event purchaser will be entitled to take delivery of the goods or the materials sold within such extended Delivery period.

36.3.9 If contractor fails to lift sold scrap within the specified period, penalty shall be levied at the rate of 0.5% per day of the value of un-removed Scrap. Moreover the material shall remain at the purchaser's risk until removal thereof. Further BNPMIPL will be entitled to charge the ground rent as stated in relevant Para of SCC, for the area in which the materials sold are kept or stored — which would be recovered by the BNPMIPL from the Purchaser before removal of the material and In the event of default in payment thereof, the BNPMIPL at may its discretion shall be entitled to order the re-sale of such materials and forfeit the Security deposit or sale amount or both, paid by the purchaser.

36.3.10 If the purchaser makes slow progress with his contract and the BNPMIPL is of opinion that he may fail to fulfill the contract within the time specified in the conditions of sale, it will be lawful for the BNPMIPL to cancel the whole contract or such portion thereof as may not have been completed and the BNPMIPL shall be at liberty to dispose off the goods in any manner at the risk and expense of the purchaser.

36.3.11 The purchaser will have to comply with the provisions of the Contract Labour (Regulations and Abolition Act 1970 and Central Rules 1971 and obtain license from the Assistant Labour Commissioner or the competent authorities empowered to issue such license. Any failure on the part of the purchaser in this regard will be at his risk and consequences. He shall comply with Workman's Compensation Act 1923, Payment of Wages Act 1936, and Minimum Wages Act 1948 and all the other related statutory and legal provisions and obligations, The purchaser shall also indemnify the BNPMIPL against any claim / liabilities that may occur to the contractor's labours and servants due to any reasons whatsoever.

36.3.12 If the purchaser makes default in complying with any of the condition of the contract, the sale of lot or lots in respect of which such default is made may be cancelled and such lot or lots may be put up again for sale and in such an event if a lower price is offered and accepted for such lot or lots then the purchaser shall be liable to pay the difference in price thereof together with all expenses occasioned by such resale in default to the BNPMIPL provided further that the purchaser in default shall not be entitled to claim any profit which may arise from such resale.

37. Integrity Pact – **NOT APPLICABLE**

37.1 If the tender value is above 10 Crore, the Contractor shall sign the Integrity Pact as per the prescribed format (Section XX).

SECTION V – SPECIAL CONDITIONS OF CONTRACT

The following Special Conditions of Contract (SCC) will apply for this purchase. The corresponding clauses of General Conditions of Contract (GCC) relating to the SCC stipulations have also been incorporated below. These Special Conditions will modify / substitute / supplement the corresponding (GCC) clauses.

Whenever there is any conflict between the provision in the GCC and that in the SCC, the provision contained in the SCC shall prevail.

(Clauses of GCC listed below include a possibility for variation in their provisions through SCC. There could be other clauses in SCC as deemed fit)

Sl. No.	GCC Clause No.	Topic	SCC Provision
1.	1 to 5	Definitions; Interpretation and Abbreviations, Application, Use of contract documents and information, Patent Rights, Country of Origin	No Change
2.	6	Performance Security	<p>Within twenty-one days after the issue of notification of award by BNPM, the supplier shall furnish performance security to BNPM for an amount equal to Five per cent (5%) of the total value of the contract*, valid up to sixty days after the date of completion of all contractual obligations by the supplier. Performance security may be furnished as Insurance Surety Bonds / Account Payee Demand Draft / Fixed Deposit Receipt from a commercial bank / Bank Guarantee (incl. e-Bank Guarantee) issued/confirmed from any of the commercial bank in India / Online payment in an acceptable form.</p> <p>*Total value of the contract for furnishing of Performance Bank Guarantee shall be computed based on the cumulative yearly estimated schedule(s) wise quantity for which successful bidder(s) are eligible for award of contract.</p> <p>No change for other clauses.</p>
3.	7 to 15	Technical Specifications and Standards, Packing and Marking, Inspection and Quality Control, Terms of Delivery, Transportation of Goods, Insurance, Spare parts, Incidental Services, Distribution of Dispatch Documents for Clearance/ Receipt of Goods	<p>Clause 7, 9 – 15: No Change</p> <p>Clause 8 – Packing & Marking: Refer <i>clause (4)</i> of Section VI – List of Requirements for detailed packing & marking instructions.</p>
4.	16	Warranty	Not applicable

SECTION V – SPECIAL CONDITIONS OF CONTRACT

Sl. No.	GCC Clause No.	Topic	SCC Provision
5.	17 & 18	Assignment, Sub Contracts	No Change
6.	19	Modification of contract	No Change
7.	20 & 21	Prices, Taxes and Duties	No Change
8.	22	Terms and Mode of Payment	a. 100% amount of the invoiced value shall be released within 30 days on receipt and acceptance of goods by the consignee at destination and on production of all required documents by the supplier. b. Payment shall be done in INR only.
9.	23 to 32	Delay in the supplier's performance, Liquidated damages, Custody and Return of BNPM's Materials/ Equipment/ Documents loaned to Contractor, Termination for default, Termination for insolvency, Force Majeure, Termination for convenience, Governing language, Notices, Code of Ethics	Clause 24: If the supplier fails to deliver any or all of the goods within mutually agreed delivery schedules , BNPM shall, without prejudice to other rights and remedies available to BNPM under the contract, deduct from the contract price, as liquidated damages, a sum equivalent to the 0.5% (Half) percent of the delivered price of the delayed goods for each week of delay or part thereof until actual delivery, subject to a maximum deduction of 10% of the delayed goods' contract price(s). Clause no. 26 of GCC to be read along with point no. 16. No Change for other clauses
10.	33	Resolution of disputes	Arbitration proceedings will be held at Mysuru and venue of arbitration will be Mysuru.
11.	34-35	Applicable Law, Secrecy	GCC: Clause 34.3 - Courts of Mysuru shall alone have Jurisdiction to decide on any dispute arising out or in respect of the contract. Other Clauses – No change
12.	36-37	Disposal / Sale of Scrap by Tender, Integrity Pact	Not applicable to this tender

SPECIFIC TERMS AND CONDITIONS OF CONTRACT:

13. Tax deduction at source: All statutory deduction as applicable shall be deducted at source as per rules at prevailing rates, unless certificate, if any, for deduction at lesser rate or nil deduction is submitted by the Successful bidder from appropriate authority. The successful bidder shall provide accurate particulars of PAN number as required, under Section 206AA of Income Tax Act 1961.

14. Rejection Replacement: In case material supplied is not meeting specification provided in the tender, then the material will be rejected outright and the rejected material shall be taken back within mutually agreed time period at the cost and risk of the successful bidder and replacement shall be

SECTION V – SPECIAL CONDITIONS OF CONTRACT

made within mutually agreed time period from the date of intimation. No payment shall be made for rejected item. If the material is not taken back within the stipulated period, BNPM reserves the right to dispose-off the material at the risk and expense of the bidder as per provision under Section IV: General conditions of contract.

15. Risk Purchase Clause: If the supplier fails to abide by the terms and conditions of this agreement, or fails to supply the material / service as per the delivery schedule or any time repudiates the contract, the purchaser will have the right to

a) Procure the tender item / render service from other agencies at the risk and cost of the supplier. The cost difference between the alternative arrangement and existing contract value wherein default has been made will be recovered from the supplier along with the other incidental charges.

b) Appropriate the Security Deposit (by invoking the Performance bank guarantee) deposited by the successful bidder as per clause 6.0 of GCC.

In case of procurement through alternative sources, if procurement price is lower than the existing contract value wherein default has been made, in such case no benefit on this account shall be passed on to the supplier.

16. Fore Closure Clause: If at any time during the continuation of this contract, the use of material ordered in this contract is completely banned or due to drastic change in Government policy its use as, raw material is discontinued or is declared hazardous to public health or cause rising to civil commotion, epidemics, wide-spread strikes and 21 days' notice of such eventualities is given by purchaser to the seller, the seller without any right to enforce the contract, will agree to the fore-close the performance of balance portion of this contract and in that event no claim for damages or loss will be lodged against the purchaser.

17. Vendor Performance: Vendor shall be evaluated for their performance. The performance shall be based on timeliness of deliveries, quality of the material supplied, technical support, quality of after-sales service if any, replacement of the defective material if any, responsiveness etc.

Based on the above criteria, the vendor shall be rated in category "A", "B" & "C". The vendor with rating "C" shall be disqualified/debarred from participating in the tender for certain period.

18. Preference for Micro and Small Enterprises (MSE) & Make in India (MII):

a) **MSE:** Public procurement policy for Micro and Small Enterprises (MSEs) order, 2012 as notified by Govt. of India (GOI) along with its amendments as available in www.msme.gov.in shall be applicable to this tender.

i. MSEs should have valid UDYAM Registration Certificate to be eligible for consideration under preference for Micro and Small Enterprises (*MSEs).

ii. Purchase Preference policy shall be out of purview for "TRADER" category bidders as per UDYAM.

iii. Purchase Preference benefit will be given to those bidders, who are registered under tendered item group (NIC code – 2220).

b) **MII:** The provisions of the Public Procurement (Preference to Make in India) Order 2017 dated June 15, 2017 (and subsequent amendments, if any) by Department of Industrial Policy and Promotion, GoI shall apply to this tender to the extent feasible. In terms of the DIPP Order on Preference to make in India, the local supplier shall provide:

i. Percentage of local content;

ii. A self -certification that the security thread offered meets the minimum local content;

iii. Details of the location (s) at which the local value addition is made.

Bidder has to submit declaration as per Annexure – E: Declaration under Make in India.

SECTION V – SPECIAL CONDITIONS OF CONTRACT

False declarations will be in breach of the Code of Integrity under Rule 175(1)(i)(h) of the General Financial Rules for which a bidder or its successors can be debarred for up to two years as per Rule 151 (iii) of the General Financial Rules along with such other actions as may be permissible under law.

Definitions under Make in India:

Local Content: 'Local content' means the amount of value added in India which shall, unless otherwise prescribed by the Nodal Ministry, be the total value of the item procured (excluding net domestic indirect taxes) minus the value of imported content in the item (including all customs duties) as a proportion of the total value, in percent.

$$\text{Local Content} = \frac{\text{Sale price} - \text{Value of imported content}}{\text{Sale Price}} \times 100$$

Where, "Sale price" means price excluding net domestic indirect taxes and "Value of imported content" means price of imported content inclusive of all customs duties.

Explanatory notes for calculation of local content given above:

- a. The cost of transportation, insurance, installation, commissioning, training and after sales service support like AMC/CMC etc. will not be taken into account for calculating local content in any item.
- b. Imported items sourced locally from resellers/distributors shall be excluded from calculation of local content.
- c. The license fees/royalties paid/ technical charges paid out of India shall be excluded from local content calculation.
- d. Procurement/Supply of repackaged/refurbished/rebranded imported products as understood commonly shall be treated as reselling of imported products and shall be excluded from calculation of local content. The definition of repackaged/refurbished/rebranded imported products is as follows;
'Refurbishing' means repair or reconditioning of an imported product does not amount to manufacture because no new goods come into existence.
'Repackaging' means repacking of imported goods from bulk pack to smaller packs would not ordinarily amount to manufacture of a new item.
'Rebranding' means relabeling or renaming or change in symbol or logo/ makes or corporate image of a company/ organization/ firm for an imported product would amount to rebranding.
- e. To ensure that imported items sourced locally from resellers/distributors are excluded from calculation of local content, procuring entities to obtain from bidders, the cost of such locally-sourced imported items (Inclusive of taxes) along with break-up on license/royalties paid/technical expertise cost etc. sourced from outside India. For items sold by bidder as reseller, OEM certificate for country of origin to be submitted.
- f. For contracts involving supply of multiple items, weighted average of all items to be taken while calculating the local content.

Margin of Purchase Preference: Margin of Purchase Preference means the maximum extent to which the price quoted by a "Class-I local supplier" may be above the L1 for the purpose of purchase preference. The margin of purchase preference shall be 20%.

- **Class – I Local supplier:** Minimum local content 50%.
- **Class – II Local supplier:** Minimum local content 20%.
- **Non-Local supplier:** Local content less than 20%.

SECTION V – SPECIAL CONDITIONS OF CONTRACT

Note: Bidder's intending to avail purchase preference under MSE / MII / both has to specify the same in their bid document (Techno-commercial part).

19. Conflict of Interest: Bidders having a conflict of interest shall not be eligible to participate in the tender process unless the conflict stemming from such relationship has been resolved in a manner acceptable to the Procuring Entity throughout the Tender process and execution of the Contract. Bidder have to abide by the code of integrity of public procurement. The bidder shall be considered to have a conflict of interest in this tender process and execution of the resultant contract in the following situations:

- a) If its personnel have a close personal, financial, or business relationship with any personnel of the procuring entity who are directly or indirectly related to the procurement or execution process of the contract, which can affect the decision of the procuring entity directly or indirectly;
- b) The bidder (or his allied firm as defined by DOE, MOF, GOI) provided services for the need assessment/procurement planning of the Tender process in which it is participating;
- c) A Principal can authorize only one agent, and an agent should not represent or quote on behalf of more than one Principal. However, this shall not debar more than one Authorised distributor (with/ or without the OEM) from quoting equipment manufactured by an Original Equipment Manufacturer (OEM) in procurements under Proprietary Article Certificate or
- d) A bidder participates in more than one bid in this tender process. Participation in any capacity by a Bidder (including the participation of a Bidder as a partner/ JV member or sub-contractor in another bid or vice-versa) in more than one bid shall result in the disqualification of all bids in which he is a party. However, this does not limit the participation of an entity as a sub-contractor in more than one bid if he is not bidding independently in his own name or as a member of a JV.

20. Obligations by bidders:

- a. All bidders are obliged under the CIPP (Code of integrity of public procurement) to suo moto proactively declare any conflict of interest (As per conflict-of-Interest clause), pre-existing or as and as soon as these arise at any stage) in any procurement process or execution of contract. Failure to do so would amount to violation of this Code of Integrity; and
- b. Any bidder must declare, whether asked or not in a bid document, any previous transgressions of such a Code of Integrity with any entity in any country during the last 3 (Three) years or of being debarred by any other Procuring Entity. Failure to do so would amount to violation of this code of integrity;

21. Divisibility & split ability of contract: This tender is divisible & splittable.

22. Security and Confidentiality: BNPMIPL is a security organization and the premise is declared as 'Prohibited Area' by the Govt. of Karnataka. Hence the service provider has to abide by the security rules of the Company.

(To be signed & stamped and submitted along with Techno-commercial Bid Part -I)

SECTION VI – LIST OF REQUIREMENTS

Schedule No.	Brief Description of Goods	*Tentative Quantity / year (with unit)	Earnest Money Deposit (EMD) {INR}	Remarks
1.	Supply of Angle Board (Edge Protector) at BNPM, Mysuru.	1,20,000 Nos	Rs. 64,000/- (Rupees Sixty-Four Thousand only)	a) Refer Section – VII for Technical Specifications.
2.	Supply of L-Shaped Edge Protector at BNPM, Mysuru.	1,20,000 Nos		b) Refer Section- III (SIT) for EMD Exemption.
*Quantity mentioned above is only an anticipation without any commitment. Refer clause 50 of Section II – GIT of tender for details.				

- 1. Period of Contract:** The annual rate contract shall be entered with the successful bidder(s) for a period of (01) one year from date of LOI/Contract. However, the contract can be terminated at any point of time at the discretion of BNPMIPL.
- 2. Delivery Schedule:** Delivery schedules against supply orders shall be intimated from time to time and shall be fixed upon mutual acceptance of BNPM & successful bidder(s). If successful bidder(s) fails to arrive at consensus within 1 week from date of receipt of delivery schedule from BNPM, then such schedule shall become binding on the successful bidder(s) unless rescinded/ amended by BNPM. Required size & quantity of the product shall be intimated by BNPM from time to time based on the production plan. No change in the delivery schedule shall be permitted without the written consent of BNPM.
- 3. Required Terms of Delivery:** F.O.R – BNPMIPL, Mysuru basis inclusive of P&F, Freight, Transit Insurance and any other charges to deliver at Engineering Stores, BNPM, Mysuru.
- 4. Packing & Marking (applicable for both schedules):**
 - a) 30/60 bundles of Angle Board (approx. 3,000 Nos/pallet) may be arranged on the wooden pallet.
 - b) Every stack should be strapped with plastic strips (along with pallets) to avoid falling & subsequent damages during transit.
 - c) Every stack should be wrapped in stretch film (above 50 microns) to form a compact block structure.
 - d) Each stack should contain packing list of contained packing materials (number of angle boards, number in each bundle, net quantity, supplier name, batch/lot number, invoice no etc.)
 - e) Supplier should provide gross weight of each pallet along with weight of packing materials (i.e. empty pallet weight, net weight, other packing materials weight).
- 5. Mode of Transportation:** As desired by the bidder which should be in safe and secured manner.

Place of Delivery:

Bank Note Paper Mill India Private Limited,
Engineering Stores,
Paper Mill Compound, Note Mudran Nagar,
Mysuru - 570 003. Karnataka.

(To be signed & stamped and submitted along with Techno-commercial Bid Part -I)



SECTION VII – TECHNICAL SPECIFICATIONS

Technical Specifications:

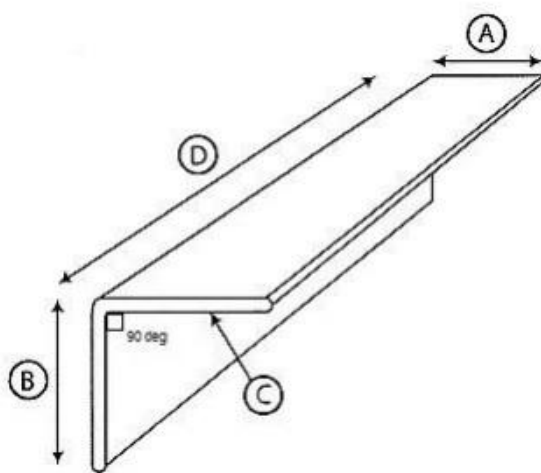
Description	Specifications				
Angle Board (Edge Protector)	<p><u>SPECIFICATION FOR ANGLE BOARD (EDGE PROTECTOR):</u></p> <p>a. Material: Paper Board.</p> <p>b. Type: Angle Board.</p> <p>c. Size (in mm): 50 * 50 * 3 (thickness) – Tolerance as provided in drawing.</p> <p>d. Length: 950 mm – Tolerance as provided in drawing.</p> <div style="text-align: center; margin: 10px 0;">  </div> <table border="1" style="margin-left: auto; margin-right: auto; border-collapse: collapse; text-align: center;"> <tr> <td style="padding: 2px 10px;">A = 50 ± 2 mm</td> </tr> <tr> <td style="padding: 2px 10px;">B = 50 ± 2 mm</td> </tr> <tr> <td style="padding: 2px 10px;">C = 3 +0.3 /-0 mm</td> </tr> <tr> <td style="padding: 2px 10px;">D = 950 ± 5 mm</td> </tr> </table>	A = 50 ± 2 mm	B = 50 ± 2 mm	C = 3 +0.3 /-0 mm	D = 950 ± 5 mm
A = 50 ± 2 mm					
B = 50 ± 2 mm					
C = 3 +0.3 /-0 mm					
D = 950 ± 5 mm					
L-Shaped (Edge Protector)	<ol style="list-style-type: none"> 1. Material – Paper board. 2. Type – L-profile angle board. 3. Dimensions – 50 mm x 50 mm (±2 mm). 4. Angle – 90° (±5°). 5. Thickness – 3 mm (+0.3 mm/ -0mm). 6. Length – 975 mm (±5 mm). 7. Moisture % – 8% (±2 %). 8. Physical requirements – <ol style="list-style-type: none"> i. Must be uniform, straight and free from defects such as blisters, delamination, or tears, ii. Crushed corners, torn faces, moisture damage, mold, excessive warp, edge cracking etc. are not acceptable. iii. Edges shall be free from burrs and sharp defects. 				

SECTION VII – TECHNICAL SPECIFICATIONS

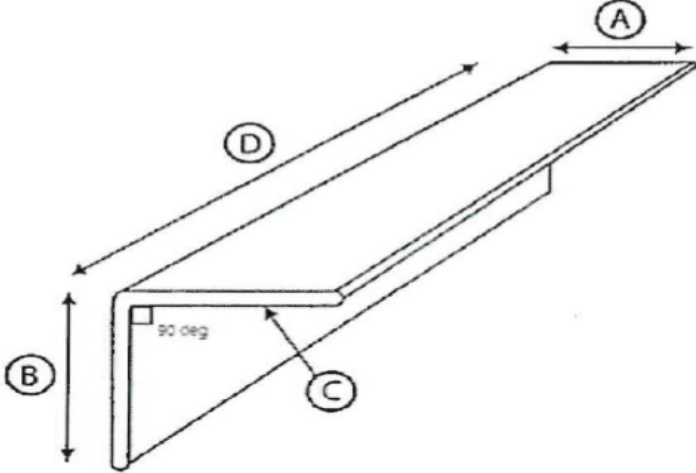
Description	Specifications				
	<p>iv. Should be free of hazardous substances.</p> <p>9. Odour – The material shall be free from any objectionable odour.</p> <p>10. Note – Test certificates should be provided by the supplier with tested values for material dimensions, thickness and moisture along with material during supply.</p> <div style="text-align: center; margin: 10px 0;">  </div> <table border="1" style="margin-left: auto; margin-right: auto; border-collapse: collapse; text-align: center;"> <tr> <td style="padding: 2px 10px;">A = 50 ± 2 mm</td> </tr> <tr> <td style="padding: 2px 10px;">B = 50 ± 2 mm</td> </tr> <tr> <td style="padding: 2px 10px;">C = 3 +0.3 /-0 mm</td> </tr> <tr> <td style="padding: 2px 10px;">D = 975 ± 5 mm</td> </tr> </table>	A = 50 ± 2 mm	B = 50 ± 2 mm	C = 3 +0.3 /-0 mm	D = 975 ± 5 mm
A = 50 ± 2 mm					
B = 50 ± 2 mm					
C = 3 +0.3 /-0 mm					
D = 975 ± 5 mm					

(To be signed & stamped and submitted along with Techno-commercial Bid Part -I)

SECTION VIII – QUALITY CONTROL REQUIREMENTS

We shall supply the material strictly as per specifications and compliance statements given below.

Technical Compliance Statement:

S No	Parameters	Requirement	Offered by bidder	Deviation, if any
SCHEDULE 1: ANGLE BOARD (EDGE PROTECTOR)				
1.	Material	Paper Board	<input type="checkbox"/> YES / <input type="checkbox"/> NO	
2.	Type	Angle Board	<input type="checkbox"/> YES / <input type="checkbox"/> NO	
3.	Angle Size	50mm * 50mm * 3mm (thickness)	<input type="checkbox"/> YES / <input type="checkbox"/> NO	
4.	Tolerance for Angle Depth	±2mm	<input type="checkbox"/> YES / <input type="checkbox"/> NO	
5.	Tolerance for Thickness	+0.3mm/-0mm	<input type="checkbox"/> YES / <input type="checkbox"/> NO	
6.	Length	950mm	<input type="checkbox"/> YES / <input type="checkbox"/> NO	
7.	Tolerance for Length	±5mm	<input type="checkbox"/> YES / <input type="checkbox"/> NO	
SCHEDULE 2: L-SHAPED (EDGE PROTECTOR)				
1.	Material	Paper board	<input type="checkbox"/> YES/ <input type="checkbox"/> NO	
2.	Type	L-profile angle board	<input type="checkbox"/> YES/ <input type="checkbox"/> NO	
3.	Dimensions	50 mm x 50 mm (± 2 mm)	<input type="checkbox"/> YES/ <input type="checkbox"/> NO	
4.	Angle	90° (±5°)	<input type="checkbox"/> YES/ <input type="checkbox"/> NO	
5.	Thickness	3 (+0.3 mm/ -0mm)	<input type="checkbox"/> YES/ <input type="checkbox"/> NO	
6.	Length	975 (±5 mm)	<input type="checkbox"/> YES/ <input type="checkbox"/> NO	
7.	Moisture %	8 % (±2 %).	<input type="checkbox"/> YES/ <input type="checkbox"/> NO	
8.	Physical requirements	Material shall be uniform, straight and free from defects such as blisters, delamination, or tears, crushed corners, torn faces, moisture damage, mold, excessive warp, edge cracking etc. Edges shall be free from burrs	<input type="checkbox"/> YES/ <input type="checkbox"/> NO	

SECTION VIII – QUALITY CONTROL REQUIREMENTS

S No	Parameters	Requirement	Offered by bidder	Deviation, if any
		and sharp defects. Material shall be free of hazardous substances.		
9.	Odour	The material shall be free from any objectionable odour.	<input type="checkbox"/> YES/ <input type="checkbox"/> NO	
10.	Test Certificates	Test certificates should be provided by the supplier with tested values for material dimensions, thickness and moisture along with material during supply.	<input type="checkbox"/> YES/ <input type="checkbox"/> NO	
PACKING & MARKING (APPLICABLE TO BOTH SCHEDULES)				
11.	Packing & Marking	We agree to the instructions for packing & marking as provided in Clause (4) of Section VI – List of Requirements for both schedules.	<input type="checkbox"/> YES/ <input type="checkbox"/> NO	

* Bidder has to fill:

YES – In case specification remains exactly same in the offered product.

NO – In case specification does not match with the offered product and deviation from the specification is to be provided below at the designated place.

(Acceptance to deviations shall be at sole discretion of BNPM. In case of non-acceptance of deviations, bid is liable to be rejected. Interested bidders may get pre-clarifications to technical deviations from BNPM prior to submission of bid to avoid rejection of bids at a later stage)

(To be signed & stamped and submitted along with Techno-commercial Bid Part –I)

COMMERCIAL COMPLIANCE STATEMENT

Sl. no.	Features	Requirements of BNPMIPL, Terms & conditions	Whether Agreed by the firm	Deviation, if any
01	General Conditions for supply	Supply/Services shall be rendered exactly as per the instructions mentioned in the Section VI & VII.	Yes agreed	
02	Technical Specifications	As per the specifications/scope of work provided in Section VII under Technical Specifications.	Yes agreed	
03	Quantity	As indicated in Section VI - List of Requirement.	Yes agreed	
04	Delivery	As indicated in Section VI - List of Requirement.	Yes agreed	
05	Payment terms	Payment terms as mentioned in point 8 of SCC	Yes agreed	
06	Liquidated Damages	As per liquidated damages clause mentioned in the tender.	Yes agreed	
07	Performance security	As per performance security clause mentioned in the tender. (SCC Clause: 2)	Yes agreed	
08	Warranty	As per warranty clause mentioned in the tender. (SCC Clause: 4)	Yes agreed	
09	Tender terms & conditions	We have gone through entire tender document thoroughly including GIT (Section II - General Instructions to Tenderer), GCC (Section IV - GENERAL CONDITIONS OF CONTRACT) <u>and confirm that we don't have any counter conditions.</u> We also understand that offer with counter conditions is liable for rejection.	Yes agreed	
10	Compliance to SIT & SCC clauses	SIT Clause: Sl.no. 1 to Sl.no. 20. SCC Clause: Sl.no. 1 to Sl.no. 22.	Yes agreed	
11	No. of pages	Total number of pages in Technical Bid		

Authorized signatory & stamp

(To be signed & stamped and submitted along with Techno-commercial Bid Part -I)

SECTION IX – QUALIFICATION/ ELIGIBILITY CRITERIA

Category	Eligibility Criteria	Documents required in support of eligibility criteria												
General	<p>a) Bidder* (Individual/ firm/ company/ corporate / LLP / HUF / limited company) intending to bid should be bonafide, experienced, technically competent, resourceful and financially sound to carry out the assigned order.</p> <p>*Any bidder from a country which shares a land border with India will be eligible to bid in the tender only if the bidder is registered with the Competent Authority (The Registered Committee constituted by the Department for Promotion of Industry and Internal Trade).</p>	<p>Company's registration / Certificate of incorporation and MOA & AOA /Partnership Deed/Any other registration certificate as applicable.</p> <p>Signed & Stamped Annexure - A on company's letter head.</p>												
	b) Bidder should have valid GST registration certificate.	Copy of GST certificate.												
	c) Bidder should have valid PAN card.	Copy of PAN card.												
	d) As on the date of submission of bid against this tender, bidder should not be in the list of ineligible/ blacklisted/ banned/ debarred entity by SPMCIL/ BRBNMPL/ BNPMIPL/any Government Agency for participating in its tenders.	Declaration as per Annexure-B on company's letter head duly Signed & with company Stamp to be submitted.												
Experience & Past Performance	<p>a) Bidder should have supplied Angle Boards/ Edge Protectors/ items of *similar nature as given in table below in any 1 (One) year of last 5 (Five) years ending 31.01.2026.</p> <table border="1" style="margin-left: auto; margin-right: auto; border-collapse: collapse; text-align: center;"> <thead> <tr> <th style="width: 10%;">Sl No</th> <th style="width: 40%;">If quoted for</th> <th style="width: 50%;">Minimum supplied Qty</th> </tr> </thead> <tbody> <tr> <td>1.</td> <td>Schedule-1</td> <td>36,000 Nos / 34,200 Meters</td> </tr> <tr> <td>2.</td> <td>Schedule-2</td> <td>36,000 Nos / 35,100 Meters</td> </tr> <tr> <td colspan="2">Total (Cumulative) Qty</td> <td>72,000 Nos / 69,300 Meters</td> </tr> </tbody> </table>	Sl No	If quoted for	Minimum supplied Qty	1.	Schedule-1	36,000 Nos / 34,200 Meters	2.	Schedule-2	36,000 Nos / 35,100 Meters	Total (Cumulative) Qty		72,000 Nos / 69,300 Meters	<p>The bidder shall submit copy of signed:</p> <ol style="list-style-type: none"> i. Purchase order / Work order / Agreement / Contract. ii. Tax Invoice. iii. Documents evidencing supply of material (viz. LR/E-way bill/GSTR etc.). <p>Note:</p> <p>e) BNPM reserves the right to seek additional documents related to the documents submitted against eligibility criteria.</p> <p>f) The start-ups should be recognized by DPIIT and certificate of recognition issued by DPIIT clearly stating the "sector" & "industry" corresponding to item in the tender should be submitted along with the bid. In case of unavailability of corresponding sector / industry in the certificate, bidder should submit documents approved/ accepted by DPIIT substantiating relevance to</p>
	Sl No	If quoted for	Minimum supplied Qty											
1.	Schedule-1	36,000 Nos / 34,200 Meters												
2.	Schedule-2	36,000 Nos / 35,100 Meters												
Total (Cumulative) Qty		72,000 Nos / 69,300 Meters												
<p>b) For Start-up bidders: Criteria is relaxed for Start-ups recognized by DPIIT. Start-ups having capability to execute the supply as per the quality & technical specifications specified in the tender should have supplied Angle Boards/ Edge Protectors/ items of *similar nature as given in table below in any 1 (One) year of last 5 (Five) years ending 31.01.2026.</p>														

SECTION IX – QUALIFICATION/ ELIGIBILITY CRITERIA

	<table border="1" style="width: 100%; border-collapse: collapse;"> <tr> <th style="width: 10%;">Sl No</th> <th style="width: 20%;">If quoted for</th> <th style="width: 10%;">Minimum supplied Qty</th> </tr> <tr> <td style="text-align: center;">1.</td> <td>Schedule-1</td> <td>25,200 Nos / 23,940 Meters</td> </tr> <tr> <td style="text-align: center;">2.</td> <td>Schedule-2</td> <td>25,200 Nos / 24,570 Meters</td> </tr> <tr> <td colspan="2">Total (Cumulative) Qty</td> <td>50,400 Nos / 48,510 Meters</td> </tr> </table> <p>*Similar in nature shall mean items that serve the same purpose as that of angle board / edge protector.</p> <p>Note: Bidders quoting in more than one schedule must have supplied cumulative quantity (i.e. Total quantity).</p>	Sl No	If quoted for	Minimum supplied Qty	1.	Schedule-1	25,200 Nos / 23,940 Meters	2.	Schedule-2	25,200 Nos / 24,570 Meters	Total (Cumulative) Qty		50,400 Nos / 48,510 Meters	<p>the item in the tender.</p>				
Sl No	If quoted for	Minimum supplied Qty																
1.	Schedule-1	25,200 Nos / 23,940 Meters																
2.	Schedule-2	25,200 Nos / 24,570 Meters																
Total (Cumulative) Qty		50,400 Nos / 48,510 Meters																
Financial Standings	<p>a) Average annual turnover ^[Ref Note (i)] of the bidder firm during last three financial year's period ending 31.03.2025 should be as given in below table,</p> <table border="1" style="width: 100%; border-collapse: collapse;"> <tr> <th style="width: 40%;">If quoted for</th> <th style="width: 60%;">Minimum Annual turnover</th> </tr> <tr> <td style="text-align: center;">Schedule-1</td> <td style="text-align: center;">Rs. 4,68,340/-</td> </tr> <tr> <td style="text-align: center;">Schedule-2</td> <td style="text-align: center;">Rs. 4,89,250/-</td> </tr> <tr> <td>Total (Cumulative)</td> <td style="text-align: center;">Rs. 9,57,590/-</td> </tr> </table> <p>b) For Start-up bidders: Turnover criteria is relaxed for Start-ups recognized by DPIIT. Such start-ups are required to have an average annual turnover as given in table below during last three financial year's period ending 31.03.2025.</p> <table border="1" style="width: 100%; border-collapse: collapse;"> <tr> <th style="width: 40%;">If quoted for</th> <th style="width: 60%;">Minimum Annual turnover</th> </tr> <tr> <td style="text-align: center;">Schedule-1</td> <td style="text-align: center;">Rs. 3,27,840/-</td> </tr> <tr> <td style="text-align: center;">Schedule-2</td> <td style="text-align: center;">Rs. 3,42,475/-</td> </tr> <tr> <td>Total (Cumulative)</td> <td style="text-align: center;">Rs. 6,70,315/-</td> </tr> </table> <p>Note: If quoting more than one schedule bidders should have cumulative annual turnover (i.e. Total).</p> <p>c) Net worth of the bidder firm should not be in negative as on 31.03.2025 and should have not eroded ^[Ref Note (ii)] by more than 30% (Thirty percent) year-on-year basis as well as cumulative basis in the last three financial year's period ending 31.03.2025.</p>	If quoted for	Minimum Annual turnover	Schedule-1	Rs. 4,68,340/-	Schedule-2	Rs. 4,89,250/-	Total (Cumulative)	Rs. 9,57,590/-	If quoted for	Minimum Annual turnover	Schedule-1	Rs. 3,27,840/-	Schedule-2	Rs. 3,42,475/-	Total (Cumulative)	Rs. 6,70,315/-	<p>Audited balance sheet and profit & loss statement for FY: 2024-25, FY: 2023-24, FY: 2022-23 and FY: 2021-22.</p> <p>Chartered Accountants certificate for Turnover, Profit and Net worth may be accepted for the bidders, where tax audit has been exempted as per the existing Govt. orders issued before tender closing date.</p> <p>Note: The start-ups should submit certificate of recognition issued by DPIIT.</p>
If quoted for	Minimum Annual turnover																	
Schedule-1	Rs. 4,68,340/-																	
Schedule-2	Rs. 4,89,250/-																	
Total (Cumulative)	Rs. 9,57,590/-																	
If quoted for	Minimum Annual turnover																	
Schedule-1	Rs. 3,27,840/-																	
Schedule-2	Rs. 3,42,475/-																	
Total (Cumulative)	Rs. 6,70,315/-																	
<p>Note:</p> <p>i. If the date of constitution/ incorporation of the bidder's firm is less than three financial years, then the average annual financial turnover during the last two years/ last financial year (as the case may be) should be at least as mentioned in clause (a) of Financial Standings mentioned above.</p>																		

SECTION IX – QUALIFICATION/ ELIGIBILITY CRITERIA

- ii. Erosion shall be calculated only on account of reported loss in the statement of P&L account, which has led to reduction in capital. Net-worth (NW) erosion will be calculated as below,

Year - on - Year basis	Cumulative basis
$\frac{(\text{NW of FY 2024-25 (-) NW of FY 2023-24})}{(\text{NW of FY 2023-24})}$	$\frac{(\text{NW of FY 2024-25 (-) NW of FY 2021-22})}{(\text{NW of FY 2021-22})}$
$\frac{(\text{NW of FY 2023-24 (-) NW of FY 2022-23})}{(\text{NW of FY 2022-23})}$	
$\frac{(\text{NW of FY 2022-23 (-) NW of FY 2021-22})}{(\text{NW of FY 2021-22})}$	

- iii. BNPM reserves the right to verify all credentials submitted by bidders towards eligibility criteria.
iv. JVs/Consortiums are not allowed to participate in this tender.

- I) *Any bidder from a country which shares a land border with India will be eligible to bid in the tender only if the bidder is registered with the Competent Authority (The Registered Committee constituted by the Department for Promotion of Industry and Internal Trade).
- II) Bidder means any person or firm or company, including any member of a consortium or joint venture (that is an association of several persons, or firms, or companies), every artificial judicial person not falling in any of the descriptions of bidders stated hereinbefore, including any agency branch or office controlled by such person participating in a procurement process.
- III) “Bidder from a country which shares a land border with India” for the purpose of this order means:-
- a) An entity incorporated, established or registered in such a country; or
 - b) A subsidiary controlled through entities incorporated, established or registered in such a country, or
 - c) An entity substantially controlled through entities incorporated, established or registered in such a country, or
 - d) An entity whose beneficial owner is situated in such a country; or
 - e) An India (or other) agent of such an entity; or
 - f) A natural person who is a citizen of such a country; or
 - g) A consortium or joint venture where any member of the consortium or joint venture falls under any of the above.
- IV) The beneficial owner for the purpose of (iii) above will be as under:-
- 1) In case of a company or limited liability partnership, the beneficial owner is the natural person (s), who, whether acting alone or together, or through one or more judicial person, has a controlling ownership interest or who exercise control through other means.
- Further explanation:
- a) “Controlling ownership interest” means ownership of or entitlement to more than twenty-five per cent of shares or capital or profits of the company;
 - b) “Control” shall include the right to appoint majority of the director or to control the management or policy decision including by virtue of their shareholding or management rights or shareholder agreements or voting agreements;
- 2) In case of partnership firm, the beneficial owner is the natural person(s) who, whether acting alone or together, or through one or more judicial person, has ownership of entitlement to more than fifteen percent of capital or profits of the partnership;

SECTION IX – QUALIFICATION/ ELIGIBILITY CRITERIA

- 3) In case of an unincorporated association or body of individuals, the beneficial owner is the natural person(s), who, whether acting alone or together, or through one or more judicial person, has ownership of or entitlement to more than fifteen percent of the property or capital or profits of such association or body of individuals;
 - 4) Where no natural person is identified under (1) or (2) or (3) above, the beneficial owner is the relevant natural person who holds the position of senior managing official;
 - 5) In case of a trust, the identification of beneficial owners(s) shall include identification of the author of the trust, the trustee, the beneficiaries with fifteen percent or more interest in the trust and any other natural person exercising ultimate effective control over the trust through a chain of control or ownership.
- V) An agent is a person employed to do any act for any another, or to represent another in dealings with third persons.
- VI) The successful bidder shall not be allowed to sub contract works to any contractor from a country which shares a land border with India unless such contractor is registered with the Competent Authority.
- VII) A bidder is permitted to procure raw material, components, sub-assemblies etc. from the vendors from countries which shares a land border with India. Such vendors will not be required to be registered with the competent authority, as it is not regarded as sub-contracting.
- VIII) However, in case a bidder has proposed to supply finished goods procured directly/indirectly from the vendors from the countries sharing land border with India, such vendor will be required to be registered with the competent authority.
- IX) The registration shall be valid at the time of submission of bid and at the time of acceptance of bid.

Bidder to furnish stipulated documents in support of fulfillment of qualifying criteria. Non-submission or incomplete submission of documents may lead to rejection of offer.

All experience; past performance and capacity/ capability related/ data should be certified by the authorized signatory of the bidder firm. The credentials regarding experience and past performance to the extent required as per eligibility criteria submitted by bidder may be verified from the parties for whom work has been done.

We confirm that, we are competent and legally authorized to submit the tender and / or to enter into legally binding contract. We (Name of the company) have submitted the required documents in support of the eligibility criteria mentioned above.

Authorized Signature with stamp & date

(To be signed & stamped and submitted along with Techno-commercial Bid Part -I)

SECTION IX – QUALIFICATION/ ELIGIBILITY CRITERIA

ANNEXURE – A

e-Tender No: BNPM/NCB/526/2025-26 dated 26.02.2026.

(To be submitted on Company letterhead)

DECLARATION

I have read the clause regarding restrictions on procurement from a bidder of a country which shares a land border with India. I hereby certify that M/s is not from such a country or, if from such a country, has been registered with the Competent Authority. I hereby certify that M/s fulfills all requirements in this regard and is eligible to be considered.” (where applicable, evidence of valid registration by the Competent Authority shall be attached)

I, the undersigned, declare that the items

- (i) **ANGLE BOARD (EDGE PROTECTOR)** originates in (Name of the country).
- (ii) **L-SHAPED EDGE PROTECTOR** originates in (Name of the country).

Signature _____

Name-----

Designation-----

Date-----

Stamp of the Organization-----



SECTION IX – QUALIFICATION/ ELIGIBILITY CRITERIA

ANNEXURE – B

e-Tender No: BNPM/NCB/526/2025-26 dated 26.02.2026.

(To be submitted on Company letterhead)

DECLARATION

I) We do hereby declare that,

1. As on the date of submission of bid against this tender we are not in the list of ineligible/ blacklisted/ banned/ debarred entity by SPMCIL/ BRBNMPL/ BNPMIPL/any Government Agency, for participating in its tenders.

Further, we agree, in case we got blacklisted/ banned/ debarred by SPMCIL/ BRBNMPL/ BNPMIPL/any Government Agency, any time prior to finalization of tender/ contract, our bid shall not be considered for further evaluation/ award of order.

2. The director/proprietor of the bidding firm are not closely related to BNPMIPL.

In case, at any time the information furnished is found to be false, you may disqualify/ debar me/ us as deemed fit.

II) We do hereby declare that we have read and understood all terms and conditions of tender document including GIT, SIT, GCC, SCC, Technical Specification, Quality Control Criteria and confirm to abide to those conditions without any counter conditions.

Signature _____

Name-----

Designation-----

Date-----

Stamp of the Organization-----



SECTION IX – QUALIFICATION/ ELIGIBILITY CRITERIA

ANNEXURE – C

e-Tender No: BNPM/NCB/526/2025-26 dated 26.02.2026.

(To be submitted on Company letterhead)

DECLARATION

Table 1: Quote details:

Whether bidder has quoted for all schedules of tender?	<input type="checkbox"/> YES / <input type="checkbox"/> NO
If no, please specify the schedule for which	<input type="checkbox"/> Schedule-1 / <input type="checkbox"/> Schedule-2

Table 2: Bidders claiming relaxation under Start-up provisions:

1	Whether exemption claimed under provisions of Start-up?	<input type="checkbox"/> YES / <input type="checkbox"/> NO
2	If yes, whether Start-up is recognized by DPIIT?	DPIIT certificate no: _____
3	If recognized by DPIIT, whether documents approved/ accepted by DPIIT substantiating relevance to the goods in the tender is available & enclosed to the bid?	<input type="checkbox"/> YES / <input type="checkbox"/> NO

Table 3: Past Experience Details

Sl. No.	Description of Supply/Work	Name & Address of Customer	PO/WO/ /Agreement No. with date	Qty. of Supply / Services provided	Delivery Period
1					
2					
3					
4					
5					

Table 4: Financial Details

Sl. No.	Financial Year	Annual Turn Over (Rs.)	Networth (Rs.)
1	2024-25		
2	2023-24		
3	2022-23		
4	2021-22		

SECTION IX - QUALIFICATION/ ELIGIBILITY CRITERIA

Table 5:

Application for Purchase Preference:		
1	Whether bidder has claimed purchase preference under Public procurement policy for Micro and Small Enterprises (MSEs) Order, 2012?	<input type="checkbox"/> YES / <input type="checkbox"/> NO
(a)	If yes, NIC code(s) as per UDYAM Certificate	_____
2	Whether bidder has claimed purchase preference under Public Procurement (Preference to Make in India) Order, 2017?	<input type="checkbox"/> YES / <input type="checkbox"/> NO
(a)	If yes, Percentage of Local Content (%) claimed	_____

Signature _____

Name-----

Designation-----

Date-----

Stamp of the Organization-----



SECTION IX – QUALIFICATION/ ELIGIBILITY CRITERIA

ANNEXURE – D

e-Tender No: BNPM/NCB/526/2025-26 dated 26.02.2026.

(To be submitted on Company letterhead)

BID SECURITY DECLARATION

We, the undersigned, declare that we will automatically be suspended from being eligible for bidding in any tender with Bank Paper Mill India Private Limited, Mysuru for the period of 12 months, if we are withdrawing our Bid during the period of bid validity (or) fail / refuse to furnish the performance security / execute the contract, if awarded.

Signature _____

Name-----

Designation-----

Date-----

Stamp of the Organization-----



SECTION IX – QUALIFICATION/ ELIGIBILITY CRITERIA

ANNEXURE – E

e-Tender No: BNPM/NCB/526/2025-26 dated 26.02.2026.

(To be submitted on Company letterhead)

DECLARATION UNDER PREFERENCE TO MAKE IN INDIA POLICY

In line with Government Public Procurement Order No. P-45021/2/2017-BE-II dt. 15.06.2017 and as amended from time to time and as applicable on the date of submission of tender, we hereby certify that we, M/s _____ (supplier name) are local supplier meeting the requirement of minimum Local content as per details below for the material against Tender No _____

1. We declare to be (Tick one)

- a. Class-I Supplier (50% or more local content)
- b. Class-II Supplier (20% to 50% local content)
- c. Non-Local Supplier (Less than 20% local content)

2. Details of location at which local value addition will be made is as follows:

S No	Name of the Item	Name of Manufacturer	Country of Origin	% Value to the total cost	Location (s) and address at which the local value addition is made

We also understand, false declarations will be in breach of the Code of Integrity under Rule 175(1)(i)(h) of the General Financial Rule for which for which a bidder or its successors can be debarred for up two years as per Rule 151 (iii) of the General Financial Rules along with such other actions as may be permissible under law.

BNPM reserves the right to verify the local content in terms of the requirement of Public Procurement (Preference to Make in India) Order.

Signature _____

Name-----

Designation-----

Date-----

Stamp of the Organization-----

SECTION X- TENDER FORM

(Bidder shall use this covering letter while submitting the offer)

To

Date _____

Bank Note Paper Mill India Private Limited
Administrative Building
Entry Gate No 1, Paper Mill Compound,
Note Mudran Nagar
Mysuru 570 003
Karnataka

Ref: Your Tender document No.....dated.....

We, the undersigned have examined the above-mentioned tender enquiry document, including amendment No. -----, dated ----- (if any), the receipt of which is hereby confirmed. We now offer to supply and deliver..... (description of goods and services) in conformity with your above referred document for the sum as shown in the price schedule(s), attached herewith and made part of this tender.

If our tender is accepted, we undertake to supply the goods and perform the services as mentioned above, in accordance with the delivery schedule specified in the List of Requirements.

We further confirm that, if our tender is accepted, we shall provide you with a performance security of required amount in an acceptable form in terms of GCC clause 6, read with modification, if any, in Section V- "Special Conditions of Contract", for due performance of the contract.

We agree to keep our tender valid for acceptance for a period up to **120 days**, as required in the GIT clause 19, read with modification, if any in Section-III -"Special Instructions to Tenderers" or for subsequently extended period, if any, agreed to by us. We also accordingly confirm to abide by this tender up to the aforesaid period and this tender may be accepted any time before the expiry of the aforesaid period. We further confirm that, until a formal contract is executed, this tender read with your written acceptance thereof within the aforesaid period shall constitute a binding contract between us.

We further understand that you are not bound to accept the lowest or any tender you may receive against your above-referred tender enquiry.

(Signature with date)

(Name and designation)

Duly authorised to sign tender for and on behalf of

SECTION XI – PRICE SCHEDULE

(TO BE FILLED ONLINE ONLY THROUGH E-PORTAL)

(A copy of sealed & signed blank price schedule has to be submitted along with pre-qualification & techno-commercial offer)

Dear Sir,

SUB: PRICE BID FOR SUPPLY OF EDGE PROTECTORS ON ANNUAL RATE CONTRACT BASIS AT BNPM PLANT, MYSURU.

Ref: e-Tender No: BNPM/NCB/526/2025-26 dated 26.02.2026.

We have received and understood the above tender enquiry and are pleased to submit our price bid as under:

Sch edu le No.	Description	UOM	Q U A N T I T Y	HSN Code	Price for Supply (INR)								
					Basic unit Price (INR)	Freight, P&F, Transit Insuranc & any other charges (INR)	Unit price (Incl. of Freight, P&F, Transit Insurance & any other charges) (INR)	GST @ _%	GST Amount (INR)	Total unit price (Incl. of Freight, P&F, Transit Insurance, any other charges & GST) (INR)	Input Tax Credit for HSN/ SAC (INR)	Effective unit price (Incl. of Freight, P&F, Transit Insurance, any other charges) (INR)	Total Effective price (Incl. of Freight, P&F, Transit Insurance, any other charges) (INR)
					(b)	(c)	(d)=(b)+(c)	(%)	(e) = (d)*(%)	(f)=(d)+(e)	(g)	(h)=(f)-(g)	(i)=(h)*(a)
1.	Supply of Angle Board (Edge Protectors) at BNPM, Mysuru.	Nos	1,20,000		TO BE FILLED ONLINE IN E-TENDERING PORTAL ONLY								
2.	Supply of L-shaped Edge Protectors as per specifications at BNPM, Mysuru.	Nos	1,20,000										



SECTION XI – PRICE SCHEDULE

1. Effective unit price will be calculated based on Total unit price i.e. (Unit Price, Freight, P&F, Transit Insurance, any other charges & GST amount) less input GST amount. L-1 status shall be decided considering total effective price for each schedule.
2. Bidder shall note that no extra cost will be considered over and above the price quoted in the price bid and hence bidder shall ensure that price submitted in the price bid is quoted considering complete technical specifications/requirements/scope of work as defined in the tender document.
3. Bidder shall be eligible to pass on the input credit which has been deducted from Total price to arrive at Effective price.

Price Discrepancy:

- ii. If, in the price structure quoted by a tenderer, there is discrepancy between the unit price and the total price (which is obtained by multiplying the unit price by the quantity), the unit price shall prevail and the total price corrected accordingly, unless BNPM feels that the tenderer has made a mistake in placing the decimal point in the unit price, in which case the total price as quoted shall prevail over the unit price and the unit price corrected accordingly.
- iii. If there is an error in a total price, which has been worked out through addition and/ or subtraction of subtotals, the subtotals shall prevail and the total corrected; and
- iv. If there is a discrepancy between the amount expressed in words and figures, the amount in words shall prevail.
- v. If, as per the judgment of BNPM, there is any such arithmetical discrepancy in a tender, the same will be suitably conveyed to the tenderer by registered/speed post. If the tenderer does not agree to the observation of BNPM, the tender is liable to be ignored.

Seal ()

Name

Signature with Date

Note:

- I. Price should be quoted in e-tendering portal in **.xlsm format** provided therein under Part-II; Price bids with conditions / Counter conditions are liable for rejection.
- II. Price quoted in any other format/place shall lead to rejection of offer/term bid as unresponsive.
- III. Multiple / Variable rate for single item, shall lead to rejection of offer/term bid as unresponsive.

(To be signed & stamped and submitted along with Techno-commercial Bid Part –I)

SECTION XII – QUESTIONNAIRE

The tenderer should furnish specific answers to all the questions/ issues mentioned below. In case a question/ issue does not apply to a tenderer, the same should be answered with the remark “not applicable”.

Wherever necessary and applicable, the tenderer shall enclose certified copy as documentary proof/ evidence to substantiate the corresponding statement.

In case a tenderer furnishes a wrong or evasive answer against any of the under mentioned question/ issues, its tender will be liable to be ignored.

S. No.	Description	To be filled by bidder
1	Brief description of goods and services offered	
2	Offer is valid for acceptance up to	120 Days
3	Your permanent income tax A/c no. as allotted by the Income Tax Authority of Government of India	
4	Are you currently registered with the Government e-Marketplace (GeM), and/ or the present BNPMIPL and/ or the Directorate of Industries of the concerned State Government UDYAM/NSIC for the goods quoted? If so, indicate the date up to which you are registered and whether there is any monetary limit imposed on your registration.	Yes / No If Yes: Registration No..... Validity:
5	Are you currently registered under the Indian Companies Act, 2013 or any other similar Act? (Please attach certified copy (s) of your registration status etc. in case your answer (s) to above queries is in affirmative	
6	Bank account/NEFT/RTGS details	Name of bank: Branch: A/c No.: IFSC: MICR:
7	Please state whether business dealings with you currently stand suspended/ banned by any Ministry/ Dept. of Government of India or by any State Govt.	

SECTION XII – QUESTIONNAIRE

8	EMD details:	Online / Offline / Exempted/Not Applicable
	a) Online:	NEFT/RTGS Details: _____ Dtd: _____
	b) Offline	DD / BG No. _____ Dtd: _____
	c) Exempted:	Whether NSIC/MSE/UDYAM Reg. no: _____
9	Tender Fee:	Online / Offline
	a) Online:	NEFT/RTGS Details: _____ Dtd: _____
	b) Offline:	DD No. _____ Dtd: _____
10	We confirm that we possess the necessary technical competence and financial resources as mentioned in Section -IX of this tender document, to ensure supply of the tendered item, as per your specifications and delivery schedule. Necessary documents like copies of Work orders, P/L Accounts, Balance Sheets are enclosed	Yes / No
11	We confirm that we have quoted exactly for the tendered product as per your specifications given in Section VII	Yes / No
12	We confirm that the Price bid is quoted exactly as per your format in Section- XI	Yes / No
13	We confirm that there would not be any price escalation (Except Statutory Charges) during the supply / contract period	Yes / No
14	We confirm that we will abide by all the tender terms & conditions and we do not have any counter conditions. As required, we enclose herewith the complete set of copy of tender documents duly signed by us as a token of our acceptance	Yes / No

We also confirm that the undersigned is duly authorized and have the competence to submit the tender and / or to enter into legally binding contract for and on behalf of the firm.

.....

(Signature with date)

(Full name, Designation & address of the person duly authorized sign on behalf of the tenderer)

For and on behalf of

.....

.....

(Name, address and stamp of the tendering firm)



**NOT APPLICABLE TO THIS
TENDER DOCUMENT**

SECTION XIV- MANUFACTURER'S AUTHORIZATION FORM

**NOT APPLICABLE TO THIS
TENDER DOCUMENT**



SECTION XV- BANK GUARANTEE FORM FOR PERFORMANCE SECURITY

..... (Insert: Bank's Name, and Address of Issuing Branch or Office)

Beneficiary:

Bank Note Paper Mill India Private Limited
Administrative Building, Entry Gate 1,
Paper Mill Compound, Note Mudran Nagar,
Mysuru - 570003
Date:

Performance Guarantee No.:

WHEREAS.....(name and address of the supplier) (hereinafter called "the supplier") has undertaken, in pursuance of LOI (Letter of Intent) no..... dated to supply (description of goods and services) (herein after called "the contract").

AND WHEREAS it has been stipulated by you in the said LOI that the supplier shall furnish you with a bank guarantee by a scheduled commercial bank recognized by you for the sum specified therein as security for compliance with its obligations in accordance with the LOI;

AND WHEREAS we have agreed to give the supplier such a bank guarantee;

NOW THEREFORE we hereby affirm that we are guarantors and responsible to you, on behalf of the supplier, up to a total of..... (amount of the guarantee in words and figures), and we undertake to pay you, upon your first written demand declaring the supplier to be in default under the contract and without cavil or argument, any sum or sums within the limits of (amount of guarantee) as aforesaid, without your needing to prove or to show grounds or reasons for your demand or the sum specified therein.

We hereby waive the necessity of your demanding the said debt from the supplier before presenting us with the demand. We further agree that no change or addition to or other modification of the terms of the contract to be performed thereunder or of any of the contract documents which may be made between you and the supplier shall in any way release us from any liability under this guarantee and we hereby waive notice of any such change, addition or modification.

We undertake to pay Bank Note Paper Mill India Private Limited up to the above amount upon receipt of its first written demand, without Bank Note Paper Mill India Private Limited having to substantiate its demand.

This guarantee will remain in force for a period of sixty days after the currency of this contract and any demand in respect thereof should reach the Bank not later than the above date.

(Signature of the authorized officer of the Bank)

Name, Authorization/ Signature no. and Designation of the officer

Seal, Name & Address of the Bank and Address of the Branch



SECTION XV- BANK GUARANTEE FORM FOR PERFORMANCE SECURITY

Checklist for Bank Guarantee:

Performance BG should be in line with / comply the following.

1. BG should be issued on not less than **Rs. 300/-** e-stamp / non-judicial stamp paper in case of **paper Bank Guarantees** (or) not less than **Rs. 200/-** e-stamp in case of **e-Bank Guarantees**.
2. Non judicial stamp paper / e stamp paper should be purchased in the name of BG issuing bank only.
3. In case of e stamp paper **first party** should be **BG issuing bank** and **second party** should be **BNPM**.
4. Date of sale of non-judicial / e stamp paper shown on the BG and the stamp paper (BG) issued is not more than six months prior to the date of execution of BG.
5. Executing officer of BG should indicate his name, designation and power of attorney number / signing power no etc. on each page of BG.
6. Name and address of the supplier, name and address of BNPM and value are to be mentioned clearly.
7. Overwriting / cutting if any in BG should be authenticated under signature and seal of authorized signatory of BG issuing Bank.
8. BG number and BG date should be mentioned in all pages of BG and all pages are endorsed / signed by authorized signatories of issuing bank.
9. Amount mentioned in figures and words are to be matched.
10. Validity of BG should be in line with the terms & conditions of the contract.
11. BG should be unconditional.
12. Our Bank details is mentioned below:

Name of the Bank: **HDFC Bank.**

Name of the Branch: **Richmond Road Branch.**

Account No: **05230350002465.**

Branch Address: **No. 8/24, Salco Centre, Bangalore- 560025, Karnataka.**

IFSC: **HDFC0000523.**



SECTION XVI- CONTRACT FORM

**NOT APPLICABLE TO THIS
TENDER DOCUMENT**



**SECTION XVII- LETTER OF AUTHORITY FOR ATTENDING BID
OPENING**

**NOT APPLICABLE TO THIS
TENDER DOCUMENT**



SECTION XVIII- SHIPPING ARRANGEMENTS FOR LINER CARGOES

**NOT APPLICABLE TO THIS
TENDER DOCUMENT**

SECTION XIX- PROFORMA OF BILLS FOR PAYMENT

**NOT APPLICABLE TO THIS
TENDER DOCUMENT**



SECTION XX- PROFORMA FOR PRE-CONTRACT INTEGRITY
PACT

**NOT APPLICABLE TO THIS
TENDER DOCUMENT**

