

SECTION IV – GENERAL CONDITIONS OF CONTRACT

d) Firms or individuals shall be banned/ blacklisted after following due process, including declaring them ineligible, either indefinitely or for a stated period of time, to be awarded a BNPM contract, if it at any time determines that they have, directly or through an agent, engaged in corrupt, fraudulent, collusive or coercive practices in competing for, or in executing, a BNPM contract.

33. Resolution of disputes

33.1 If dispute or difference of any kind shall arise between BNPM and the supplier in connection with or relating to the contract, the parties shall make every effort to resolve the same amicably by mutual consultations. If the parties fail to resolve their dispute or difference by such mutual consultation within twenty one days of its occurrence, then, unless otherwise provided in the SCC, either BNPM or the supplier may seek recourse to settlement of disputes through arbitration as per The Arbitration and conciliation Act 1996 as per following clause.

33.2 Arbitration Clause: - Any dispute or difference whatsoever arising between the Parties out of or relating to the construction, meaning, scope operation or effect of this Agreement or the validity or the breach thereof shall be settled by arbitration in accordance with the Arbitration and Conciliation Act, 1996 and under the Rules of Arbitration of the Indian Council of Arbitration and the award made in pursuance thereof shall be binding on the Parties. The Arbitral Tribunal shall consist of three Arbitrators. The venue of the Arbitration shall be Bangalore and it shall be conducted in English language.

34. Applicable Law

34.1 The contract shall be interpreted in accordance with the laws of India.

34.2 Irrespective of the place of delivery, or the place of performance or the place of Payments under the contract, the contract shall be deemed to have been made at the place from which the notification of acceptance of the tender has been issued.

34.3 The courts of the place from where the notification of acceptance has been issued- shall alone have jurisdiction to decide any dispute arising out or in respect of the contract.

35. Secrecy

35.1 The Contractor shall take all reasonable steps necessary to ensure that all persons employed in any work in connection with the contract, have full knowledge of the Official Secrets Act and any regulations framed thereunder.

35.2 Any information obtained in the course of the execution of the contract by the Contractor, his servants or agents or any person so employed, as to any matter whatsoever, which would or might be directly or indirectly, of use to any enemy of India, must be treated secret and shall not at any time be communicated to any person.

35.3 Any breach of the aforesaid conditions shall entitle the Purchaser to cancel the contract and to purchase or authorise the purchase of the stores at the risk and cost of the Contractor, In the event of such cancellation, the stores or parts manufactured in the execution of the contract shall be taken by the Purchaser at such price as he considers fair and reasonable and the decision of the Purchaser as to such price shall be final and binding on the Contractor.

Part II: Additional General Conditions of Contract for specific Types of Tenders in addition/ modification to clauses mentioned above:

36. Disposal / Sale of Scrap by Tender - **NOT APPLICABLE**

36.1 During the currency of contract, no variation in price or rate shall be admissible.

36.2 Payment and Default

36.2.1 Payment may be made in the form of cash or Demand Draft /Pay order issued by any scheduled commercial bank and drawn in favour of the Account mentioned in the NIT.

36.2.2 No interest will be paid to the purchaser for the amounts paid or deposited with the BNPM and subsequently found refundable to the purchaser under any of the conditions of the contract.

36.2.3 If the purchaser fails to deposit sale value for a sold lot within the allowed period as per relevant clause BNPMIPL may forfeit the security deposit. Requests for an extension of this period, made by the purchaser may be considered by the BNPMIPL and may at its discretion, on the merits of the case, allow further time not excluding 50 days from the date of the contract. Interest shall be leviable on such amount at a rate 2% per annum higher than the PLR of State Bank of India, from the date of expiry of the payment date to actual date of payment (actual date of payment inclusive).

36.2.4 The lot or lots in respect of which forfeiture has been made, shall be deemed to have been abandoned by the purchaser to all intents and purposes and may be re-sold or otherwise disposed of at the discretion of the BNPMIPL without reference to the purchaser concerned and without incurring any liability on part of BNPMIPL whatsoever in respect there under.

36.2.5 In case extension is granted by BNPMIPL and due to late payment of sale amount the delivery cannot be completed by the purchaser, in accordance with the relevant clause of Special Conditions of Tender sale, then ground rent shall also be leviable as per relevant clause of Special Conditions of Tender sale.

36.2.6 On production of proof of having made payment, nominated authority shall issue a delivery order authorizing the purchaser to take delivery of the Scrap Materials.

36.3 Deliveries, Delays and Breach of Contract

36.3.1 The Title of goods or material sold shall not be deemed to have been passed to the Purchaser / Bidder until and unless the full and final payment has been made by the purchaser, in accordance with the contract to the BNPMIPL and the authorized Officer has issued the Delivery Order in favour of the purchaser. The materials sold may be removed from the premises only on production of the cash receipt for the payment and a delivery order from the Officer authorized by the BNPMIPL.

36.3.2 Unless specified otherwise in SIT, delivery period for lifting of material shall be within 60 days from the date of finalization of contract agreement.

36.3.3 The work of delivery will be supervised by Stock Holder or his authorized representative, representative of accounts Department and Security Staff duly authorized by BNPMIPL for the propose of delivery. Delivery will be allowed during working hours.

36.3.4 No delivery of or materials sold shall be given on Sundays, Gazetted holidays and other shall holidays observed by BNPMIPL. The delivery of the goods or material shall be effected from the premises concerned only during its normal working hours. In order to complete the delivery within the working hours all loading must cease half an hour before the normal closing time of the concerned premises. The decision of the BNPMIPL with regard to the working hour shall be final and binding on the purchaser. Purchaser will not be allowed to lift the Scrap Material from more than one location at a time.

SECTION IV – GENERAL CONDITIONS OF CONTRACT

36.3.5 The purchased stores will be carried away by the purchaser at his risk and no claims against the BNPMIPL will be entertained for shortage in weight which may be discovered after the materials have left the premises wherefrom delivery is taken. If required the purchaser shall provide his own bags, cases or other receptacles for the removal of the scrap.

36.3.6 The BNPMIPL shall not be responsible for any accident that may occur to purchaser's labours /servants for any reasons whatsoever. The purchaser will himself have to ensure the safety of his workers and shall be liable to pay claims, whatsoever if any. BNPMIPL will not carry any responsibility of such payments. The purchaser will be responsible to supply personal protection equipments to his labour/servant and staff and no additional charges are admissible for the same.

36.3.7 The materials sold, shall be removed by the purchaser within the period specified in relevant clause of Special Condition of Sale.

36.3.8 If due to any default on the part of the BNPMIPL, the purchaser is unable to remove the materials sold within the specified period, the BNPMIPL may extend the period therefore and in such an event purchaser will be entitled to take delivery of the goods or the materials sold within such extended Delivery period.

36.3.9 If contractor fails to lift sold scrap within the specified period, penalty shall be levied at the rate of 0.5% per day of the value of un-removed Scrap. Moreover the material shall remain at the purchaser's risk until removal thereof. Further BNPMIPL will be entitled to charge the ground rent as stated in relevant Para of SCC, for the area in which the materials sold are kept or stored — which would be recovered by the BNPMIPL from the Purchaser before removal of the material and In the event of default in payment thereof, the BNPMIPL at may its discretion shall be entitled to order the re-sale of such materials and forfeit the Security deposit or sale amount or both, paid by the purchaser.

36.3.10 If the purchaser makes slow progress with his contract and the BNPMIPL is of opinion that he may fail to fulfill the contract within the time specified in the conditions of sale, it will be lawful for the BNPMIPL to cancel the whole contract or such portion thereof as may not have been completed and the BNPMIPL shall be at liberty to dispose off the goods in any manner at the risk and expense of the purchaser.

36.3.11 The purchaser will have to comply with the provisions of the Contract Labour (Regulations and Abolition Act 1970 and Central Rules 1971 and obtain license from the Assistant Labour Commissioner or the competent authorities empowered to issue such license. Any failure on the part of the purchaser in this regard will be at his risk and consequences. He shall comply with Workman's Compensation Act 1923, Payment of Wages Act 1936, and Minimum Wages Act 1948 and all the other related statutory and legal provisions and obligations, The purchaser shall also indemnify the BNPMIPL against any claim / liabilities that may occur to the contractor's labours and servants due to any reasons whatsoever.

36.3.12 If the purchaser makes default in complying with any of the condition of the contract, the sale of lot or lots in respect of which such default is made may be cancelled and such lot or lots may be put up again for sale and in such an event if a lower price is offered and accepted for such lot or lots then the purchaser shall be liable to pay the difference in price thereof together with all expenses occasioned by such resale in default to the BNPMIPL provided further that the purchaser in default shall not be entitled to claim any profit which may arise from such resale.

37.1 If the tender value is above 10 Crore, the Contractor shall sign the Integrity Pact as per the prescribed format (Section XX).

37. Integrity Pact – NOT APPLICABLE

SECTION V – SPECIAL CONDITIONS OF CONTRACT

The following Special Conditions of Contract (SCC) will apply for this purchase. The corresponding clauses of General Conditions of Contract (GCC) relating to the SCC stipulations have also been incorporated below. These Special Conditions will modify / substitute / supplement the corresponding (GCC) clauses.

Whenever there is any conflict between the provision in the GCC and that in the SCC, the provision contained in the SCC shall prevail.

(Clauses of GCC listed below include a possibility for variation in their provisions through SCC. There could be other clauses in SCC as deemed fit)

Sl. No.	GCC Clause No.	Topic	SCC Provision
1.	1 to 5	Definitions; Interpretation and Abbreviations, Application, Use of contract documents and information, Patent Rights, Country of Origin	No Change.
2.	6	Performance Security	Within twenty-one days after the issue of notification of award by BNPM, the supplier shall furnish performance security to BNPM for an amount equal to 5% (Five percent) of the total value of the contract, valid up to sixty days after the date of completion of all contractual obligations by the supplier, including the warranty obligations.
3.	7 to 15	Technical Specifications and Standards, Packing and Marking, Inspection and Quality Control, Terms of Delivery, Transportation of Goods, Insurance, Spare parts, Incidental Services, Distribution of Dispatch Documents for Clearance/ Receipt of Goods	Clause 7, 8, 10 - 15: No Change Clause 9: Inspection – BNPM shall reserve the right to carry out pre-dispatch inspection (or) issue waiver for the same. In case of pre-dispatch inspection, cost of travel, lodging and boarding for BNPM representatives shall be borne by the BNPM. All other reasonable facilities and assistance, including access to relevant drawings, design details and production data shall be furnished by the supplier to BNPM's inspector at no charge to BNPM. <i>Clauses 9.1 to 9.8 of GCC shall remain applicable and unchanged.</i>
4.	16	Warranty	Applicable as per <i>clause 16 of Section IV – GCC</i> . The warranty shall remain valid for Twenty-four (24) months after the goods or any portion thereof as the case may be, have been delivered to the final destination and installed and commissioned at the final destination (i.e. BNPM, Mysuru) and accepted by BNPM in terms of the contract.

SECTION V – SPECIAL CONDITIONS OF CONTRACT

			The warranty shall be applicable for both equipment (after installation & commissioning) and operational spares & consumables (after successful commissioning of equipment).
5.	17 & 18	Assignment, Sub Contracts	<p>Clause 17: No Change.</p> <p>Clause 18: Sub-contracts – Sub-contracting is not allowed under this tender. In case of exceptional circumstances, where minor jobs (such as electrical/civil related works) are needed to be outsourced to any third party for successful completion of the contract, the successful bidder needs to obtain permission of BNPM in writing by submitting requisite documents. The total value of minor jobs (if outsourced) shall not exceed 10% of the total contract value.</p>
6.	19	Modification of contract	No Change.
7.	20 & 21	Prices, Taxes and Duties	No Change.
8.	22	Terms and Mode of Payment	<p>a) <u>For Design, Supply, Installation & Commissioning (Schedule-1):</u></p> <p>i. 70% (Seventy percent) of the total contract value shall be paid within 30 days on receipt and acceptance of goods at BNPM, Mysuru and on production of all required documents (viz. Tax Invoice, Warranty Certificate, Test Certificated etc.) by the supplier.</p> <p>ii. Balance 30% (Thirty percent) of the total contract value shall be paid after successful installation, commissioning & training and on submission of acceptance certificate issued by BNPM.</p> <p>b) <u>For Operational Spares & Consumables (Schedule-2):</u></p> <p>i. 100% of the invoice value shall be paid within 30 days on receipt and acceptance of goods at BNPM, Mysuru and on production of all required documents by the supplier.</p>
9.	23 to 32	Delay in the supplier's performance, Liquidated damages, Custody and Return of BNPM's Materials/ Equipment/ Documents	No Change.

SECTION V – SPECIAL CONDITIONS OF CONTRACT

		loaned to Contractor, Termination for default, Termination for insolvency, Force Majeure, Termination for convenience, Governing language, Notices, Code of Ethics	
10.	33	Resolution of disputes	Arbitration proceedings will be held at Mysuru and venue of arbitration will be Mysuru.
11.	34-35	Applicable Law, Secrecy	GCC: Clause 34.3 - Courts of Mysuru shall alone have Jurisdiction to decide on any dispute arising out or in respect of the contract. Other Clauses no change.
12.	36-37	Disposal / Sale of Scrap by Tender, Integrity Pact	Not applicable to this tender.

SPECIFIC TERMS AND CONDITIONS OF CONTRACT:

13. **Damage to Property:** Successful bidder will be solely responsible for making good to the satisfaction of BNPM any loss of and any damage to all structures and properties belonging to BNPM or being executed or procured by BNPM or of other agencies within the premises of the work of BNPM, if such loss or damage is due to fault and/or the negligence or wilful acts or omission of the Successful bidder, his employees, agents, representatives (if any). The Successful bidder shall indemnify and keep BNPM harmless of all claims for damage to BNPM's property arising under or by reason of this contract.
14. **Employment liability towards workers employed by the successful bidder:** The Successful bidder will be solely and exclusively responsible for engaging or employing personnel for the execution of the order. All personnel engaged by the Successful bidder shall be on Successful bidder's payroll and paid by the Successful bidder. All disputes or differences between the Successful bidder and his/their employees shall be settled by Successful bidder. BNPM has absolutely no liability whatsoever concerning the employees of the Successful bidder. The Successful bidder shall advise in writing or in such appropriate way to all of his employees and any other person engaged by Successful bidder that their appointment/employment (if any) is not by the Purchaser but by the Successful bidder and that their present appointment is only in connection with the existing contract with Purchaser and that therefore, such an employment/appointment would not enable or make them eligible for any employment/appointment with the Purchaser either temporarily or/and permanent basis.
15. **Health, Security & Safety Regulation:** Successful bidder shall comply with the Health and Safety policy of the Company (Purchaser i.e. BNPM) & should issue a certified photo-identity card to each of his employees employed for this contract and shall be authenticated by the designated security officer of BNPM. This photo-identity card should be shown to the security personnel at the entry. The successful bidder has to ensure the character and antecedent of the personnel deployed. The successful bidder must be in a position to produce such documents whenever it is asked to do so. Due to obvious security reasons, the staff deployed by the successful bidder must adhere to all rules and regulations, security restrictions as prescribed by the BNPM from time to time. The Successful bidder shall be responsible for taking precautionary measures for the safety of the workmen working under him and the responsibility arising due to any mishap during the execution of work, payment of any compensation etc., lies entirely on the part of the successful

SECTION V – SPECIAL CONDITIONS OF CONTRACT

bidder. Items required for safe working of their manpower at site are to be provided by the successful bidder. The successful bidder shall be solely responsible, at his own cost, for the supply of required PPE to his employees and he shall also ensure the use of PPE or any other equipment as required depending on nature of work by his staff at site. Successful bidder shall be solely responsible for safety of the personnel deployed at BNPM, Mysuru.

16. **Statutory compliances:** The successful bidder shall comply at its own cost with all prevailing statutory provisions and compliances as laid down and under various Labour & Labour Laws, all applicable statutes as applicable & amended from time to time. In case of violation of such statutory provisions under the labour law by the agency, there will not be any liability on BNPM and the contract will be liable for termination. The personnel deployed by the successful bidder at BNPM, Mysuru shall be covered under ESIC/ Employee Compensation Insurance / Group insurance policy (as applicable) which should be valid & premium is paid by the successful bidder till the expiry of the warranty period.
17. **Tax deduction at source:** All statutory deduction as applicable shall be deducted at source as per rules at prevailing rates, unless certificate, if any, for deduction at lesser rate or nil deduction is submitted by the Successful bidder from appropriate authority. The successful bidder shall provide accurate particulars of PAN number as required, under Section 206AA of Income Tax Act 1961.
18. **Tax Collection at source:** Finance Act, 2020 also inserted sub-section (1H) in section 206C of the Act which mandates that with effect from 1st day of October, 2020 a seller receiving an amount as consideration for sale of any goods of the value or aggregate of such value exceeding fifty lakh rupees in any previous year to collect tax from the buyer a sum equal to 0.1 per cent (subject to the provisions of proposed sub-section (10A) of the section 206C of the Act) of the sale consideration exceeding fifty lakh rupees as income-tax. The collection is required to be made at the time of receipt of amount of sales consideration.
19. **Rejection Replacement:** In case material supplied is not meeting specification provided in the tender, then the material will be rejected outright and the rejected material shall be taken back within mutually agreed time period at the cost and risk of the successful bidder and replacement shall be made within mutually agreed time period from the date of intimation. No payment shall be made for rejected item. If the material is not taken back within the stipulated period, BNPM reserves the right to dispose-off the material at the risk and expense of the bidder as per provision under Section IV: General conditions of contract.
20. **Risk Purchase Clause:** If the supplier fails to abide by the terms and conditions of this agreement, or fails to supply the material / service as per the delivery schedule or any time repudiates the contract, the purchaser will have the right to
 - a) Procure the tender item / render service from other agencies at the risk and cost of the supplier. The cost difference between the alternative arrangement and existing contract value wherein default has been made will be recovered from the supplier along with the other incidental charges.
 - b) Appropriate the Performance Security deposited by the successful bidder as per clause 6.0 of GCC.

In case of procurement through alternative sources, if procurement price is lower than the existing contract value wherein default has been made, in such case no benefit on this account shall be passed on to the supplier.

SECTION V – SPECIAL CONDITIONS OF CONTRACT

21. **Fore Closure Clause:** If at any time during the continuation of this contract, the use of material ordered in this contract is completely banned or due to drastic change in Government policy its use as, raw material is discontinued or is declared hazardous to public health or cause rising to civil commotion, epidemics, wide-spread strikes and 21 days' notice of such eventualities is given by purchaser to the seller, the seller without any right to enforce the contract, will agree to the fore-close the performance of balance portion of this contract and in that event no claim for damages or loss will be lodged against the purchaser.
22. **Obligations by bidders:**
All bidders are obliged under the CIPP (Code of integrity of public procurement) to suo moto proactively declare any conflict of interest (coming under the definition mentioned as per conflict of interest clause specified in this tender, pre-existing or as and as soon as these arise at any stage) in any procurement process or execution of contract. Failure to do so would amount to violation of this Code of Integrity; and Any bidder must declare, whether asked or not in a bid document, any previous transgressions of such a Code of Integrity with any entity in any country during the last 1 (One) year of being debarred by any other Procuring Entity. Failure to do so would amount to violation of this code of integrity.
23. **Conflict of Interest:**
Bidders having a conflict of interest shall not be eligible to participate in the tender process unless the conflict stemming from such relationship has been resolved in a manner acceptable to the Procuring Entity throughout the Tender process and execution of the Contract. Bidder have to abide by the code of integrity of public procurement. The bidder shall be considered to have a conflict of interest in this tender process and execution of the resultant contract in the following situations:
- a) If its personnel have a close personal, financial, or business relationship with any personnel of the procuring entity who are directly or indirectly related to the procurement or execution process of the contract, which can affect the decision of the procuring entity directly or indirectly;
 - b) The bidder (or his allied firm as defined by DOE, MOF,GOI) provided services for the need assessment/procurement planning of the Tender process in which it is participating;
 - c) A Principal can authorize only one agent, and an agent should not represent or quote on behalf of more than one Principal. However, this shall not debar more than one Authorized distributor (with/ or without the OEM) from quoting equipment manufactured by an Original Equipment Manufacturer (OEM) in procurements under Proprietary Article Certificate or
 - d) A bidder participates in more than one bid in this tender process. Participation in any capacity by a Bidder (including the participation of a Bidder as a partner/ JV member or sub-contractor in another bid or vice-versa) in more than one bid shall result in the disqualification of all bids in which he is a party. However, this does not limit the participation of an entity as a sub-contractor in more than one bid if he is not bidding independently in his own name or as a member of a JV.
24. **Vendor Performance:** Vendor shall be evaluated for their performance. The performance shall be based on timeliness of deliveries, quality of the material supplied, technical support, quality of after-sales service if any, replacement of the defective material if any, responsiveness etc. Based on the above criteria, the vendor shall be rated in category "A", "B" & "C". The vendor with rating "C" shall be disqualified/debarred from participating in the tender for certain period.
25. **Preference for Micro and Small Enterprises (MSE) & Make in India (MII):**
1. **MSE:** Public procurement policy for Micro and Small Enterprises (MSEs) order, 2012 as

SECTION V – SPECIAL CONDITIONS OF CONTRACT

notified by Govt. of India (GOI) along with its amendments as available in www.msme.gov.in shall be applicable to this tender.

- a. MSEs should have valid UDYAM Registration Certificate to be eligible for consideration under preference for Micro and Small Enterprises (*MSEs).
 - b. Purchase Preference policy shall be out of purview for “TRADER” category bidders as per UDYAM.
 - c. Purchase Preference benefit will be given to those bidders, who are registered under tendered item group (NIC code – 28199 / 28299).
2. **MII:** The provisions of the Public Procurement (Preference to Make in India) Order 2017 dated June 15, 2017 (and subsequent amendments, if any) by Department of Industrial Policy and Promotion, GoI shall apply to this tender to the extent feasible. In terms of the DIPP Order on Preference to make in India, the local supplier shall provide:
- a) Percentage of local content;
 - b) A self -certification that the security thread offered meets the minimum local content;
 - c) Details of the location (s) at which the local value addition is made.

Bidder has to submit declaration as per Annexure – E: Declaration under Make in India.

False declarations will be in breach of the Code of Integrity under Rule 175(1)(i)(h) of the General Financial Rules for which a bidder or its successors can be debarred for up to two years as per Rule 151 (iii) of the General Financial Rules along with such other actions as may be permissible under law.

Definitions under Make in India:

Local Content: Local content' means the amount of value added in India which shall, unless otherwise prescribed by the Nodal Ministry, be the total value of the item procured (excluding net domestic indirect taxes) minus the value of imported content in the item (including all customs duties) as a proportion of the total value, in percent.

Explanatory notes for calculation of local content given above:

- a. Imported items sourced locally from resellers/distributors shall be excluded from calculation of local content.
- b. The license fees/royalties paid/ technical charges paid out of India shall be excluded from local content calculation.
- c. Procurement/Supply of repackaged/refurbished/rebranded imported products as understood commonly shall be treated as reselling of imported products and shall be excluded from calculation of local content. The definition of repackaged/refurbished/rebranded imported products is as follows;
'Refurbishing' means repair or reconditioning of an imported product does not amount to manufacture because no new goods come into existence.
'Repackaging' means repacking of imported goods from bulk pack to smaller packs would not ordinarily amount to manufacture of a new item.
'Rebranding' means relabeling or renaming or change in symbol or logo/ makes or corporate image of a company/ organization/ firm for an imported product would amount to rebranding.
- d. To ensure that imported items sourced locally from resellers/distributors are excluded from calculation of local content, procuring entities to obtain from bidders, the cost of such locally-sourced imported items (Inclusive of taxes) along with break-up on license/royalties paid/technical expertise cost etc. sourced from outside India. For items sold by bidder as reseller, OEM certificate for country of origin to be submitted.

SECTION V – SPECIAL CONDITIONS OF CONTRACT

e. For contracts involving supply of multiple items, weighted average of all items to be taken while calculating the local content.

Margin of Purchase Preference: Margin of Purchase Preference means the maximum extent to which the price quoted by a "Class-I local supplier" may be above the L 1 for the purpose of purchase preference. The margin of purchase preference shall be 20%.

- **Class – I Local supplier:** Minimum local content 50%.
- **Class – II Local supplier:** Minimum local content 20%.
- **Non-Local supplier:** Local content less than 20%.

Note: Bidder's intending to avail purchase preference under MSE / MII / both has to specify the same in their bid document (Techno-commercial part).

26. **Security and Confidentiality:** BNPMIPL is a security organization and the premise is declared as 'Prohibited Area' by the Govt. of Karnataka. Hence the service provider has to abide by the security rules of the Company.

(To be signed & stamped and submitted along with Techno-commercial Bid Part –I)

SECTION VI – LIST OF REQUIREMENTS

Schedule No.	Brief Description of Goods / Services	Qty (with unit)	Earnest Money Deposit (EMD) {INR}	Remarks
1.	Design, Supply, Installation, Testing & Commissioning of Dust Cleaning Solution for Sheeter Machine at BNPM, Mysuru.	1 (Lump-sum)	Rs. 1,70,000/- (Rupees One Lakh Seventy Thousand only)	Refer Section – VII for Technical Specifications. Refer Section- III (SIT) for EMD Exemption.
2.	Supply of operational spares & consumables for 2 years period at BNPM, Mysuru	1 (Lump-sum)		

1. Required Delivery Schedule:

Successful bidder shall have to deliver the materials (incl. equipment, operational, recommended & essential spares and consumables., if any ordered), complete installation, commissioning and impart training to BNPM personnel within a maximum period of **26 Weeks** from date of issue of LOI/agreement/work order (whichever is earlier).

2. Required Terms of Delivery: FOR – BNPMIPL, Mysuru basis (inclusive of P&F, Freight, Transit Insurance and any other charges to deliver goods at Engineering Stores, BNPM, Mysuru and inclusive of boarding, lodging, travel charges etc. as per scope of work as given in Section VII for installation, commissioning & training.)

3. Mode of Transportation: As desired by the bidder which should be in safe and secured manner.

Place of Delivery of Material:

Bank Note Paper Mill India Private Limited,
Engineering Stores,
Paper Mill Compound, Note Mudran Nagar,
Mysuru - 570 003. Karnataka.

(To be signed & stamped and submitted along with Techno-commercial Bid Part –I)

SECTION VII – TECHNICAL SPECIFICATIONS

Design, Supply, Installation, Commissioning of Dust Cleaning System at Bank Note Paper Mill India Private Limited, Mysuru.

PURPOSE:

This document specifies the requirements of 'Design, supply, installation, testing, commissioning and training for Dust cleaning Solution' for one Sheeter.

The bidder shall supply System in accordance with the specifications mentioned herewith. Any equipment / services, if any and customisation, which may not have been specifically mentioned herein but are needed to complete the successful commissioning & operation of the system, as per requirement and site conditions, shall also be treated as included and the same shall also be furnished, unless otherwise specifically excluded as indicated.

SCOPE:

1. The scope of the work is to provide a customized Dust cleaning solution including modular brushes, static control, cleaning heads with air blowing and suction chamber, air handling unit with suitable blower/s and filters for one Sheeter machine in Finishing section.
2. Proposed system should clean the web as well as the sheet after converting. Bidder should consider for sufficient cleaning heads in the web section as well as after cross-cutter (converting) section.
3. Proposed system should clean both sides, i.e. top and bottom, of the Paper in web as well as in sheet form.
4. Proposed system should be customized as per web width of the machine to increase efficiency of dust cleaning.
5. Proposed system should be able to carry out the cleaning without effecting or altering the physical properties of the paper web.
6. Proposed system should be able to handle paper web with tension up to 400 N/m.
7. Proposed system should be able to engage/ disengage during web routing/ tears/ splice through pneumatic/ electric elements using signals from machine.
8. Proposed system should be able to start/ stop as per operation of the Sheeter machine.
9. Proposed system should not alter routing of the paper web or require installation of additional roller supports.
10. Supply, installation, and interfacing with sheeter, if any, of supplied system shall be carried out by Bidder.
11. System should have capability to provide visual/audible warnings and alarms in case of any malfunction/ routine maintenance requirement along with easy to diagnose alerts.
12. Proposed system should be CE/UL certified for health, safety, and environment standard.
13. Bidder should consider for the following:
 - (i) Supply of hardware for the system etc.,
 - (ii) Erection & installation of Hardware, Electrical & Electronics, and components of support structure.
 - (iii) All necessary power boards, cables, flexible hoses, and ducts with required length including cabling from power feeder in the MCC room.
 - (iv) Panels for housing the Electricals, Electronics and Wiring.
14. Training of BNPM O&M staff on the supplied equipment and routine/ preventive maintenance of equipment installed in the system.

SECTION VII – TECHNICAL SPECIFICATIONS

Paper Web Specifications:

1. Web width: 480 – 850 mm.
2. Web thickness: 0.1-0.15 mm.
3. Web speed: 350m / min (max).
4. Web tension: 400 N/m (max).
5. Web material: 100% Cotton pulp Paper with GSM of max.95.

Sheet Specifications:

1. Sheet width: 480 – 850 mm (+ 40mm offset operator side).
2. Sheet transport: Between 2 nos of 1.1mm thick Acrylo-NBR belts (top & bottom).
3. Sheet transport speed: 350m / min + 5%.
4. Sheet material: 100% Cotton pulp Paper with GSM of max.95.

PROPOSED MACHINE LOCATIONS:

1. **Before Cross Cutter:** (reference image below)

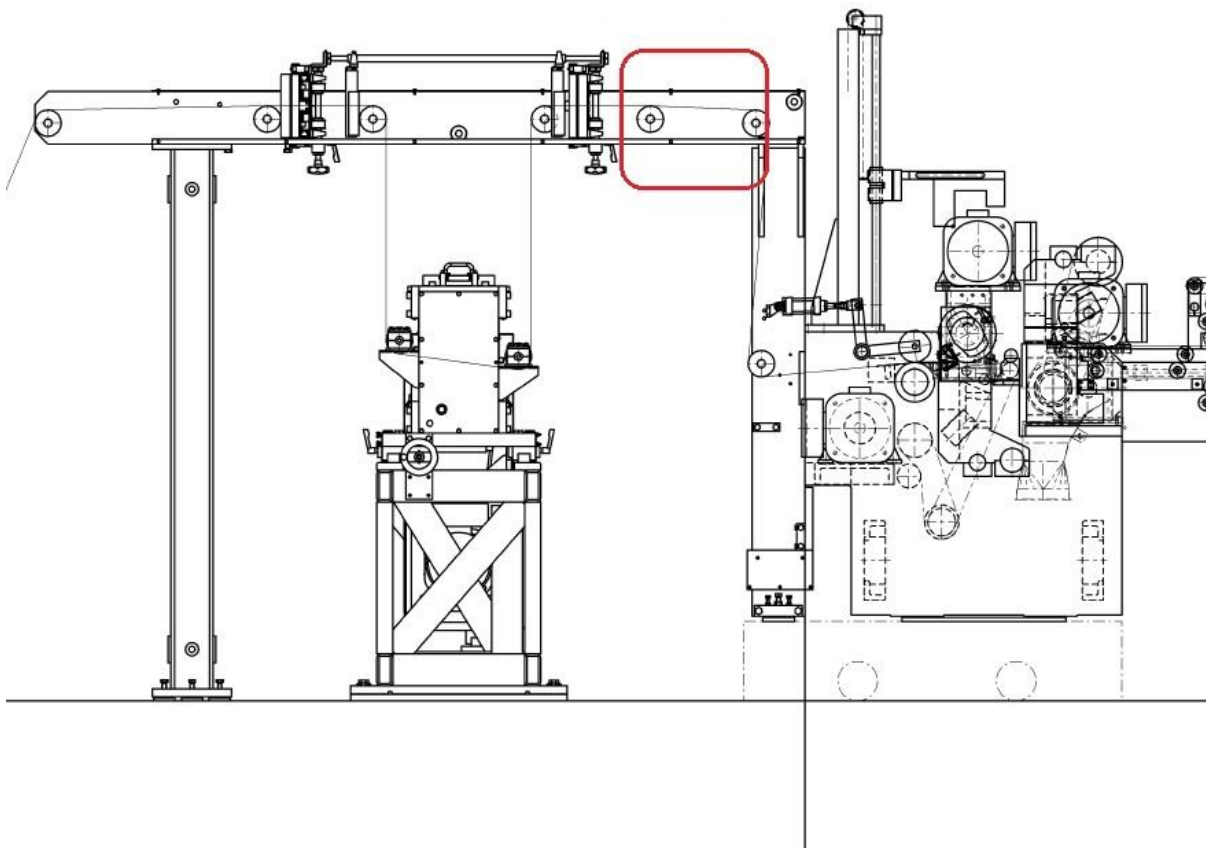

- a. Distance between rollers – 280 mm (approx.)
- b. Distance between support frames – 1580 mm (approx.)

Note: - The rollers are installed at different height (approx. 20mm difference between axis) from FFL. The position of cleaning heads should consider angle of routing of web and same is not to be disturbed. The cleaning assembly shall be customised to meet the space available.

SECTION VII – TECHNICAL SPECIFICATIONS

2. After Cross Cutter: (reference image below)

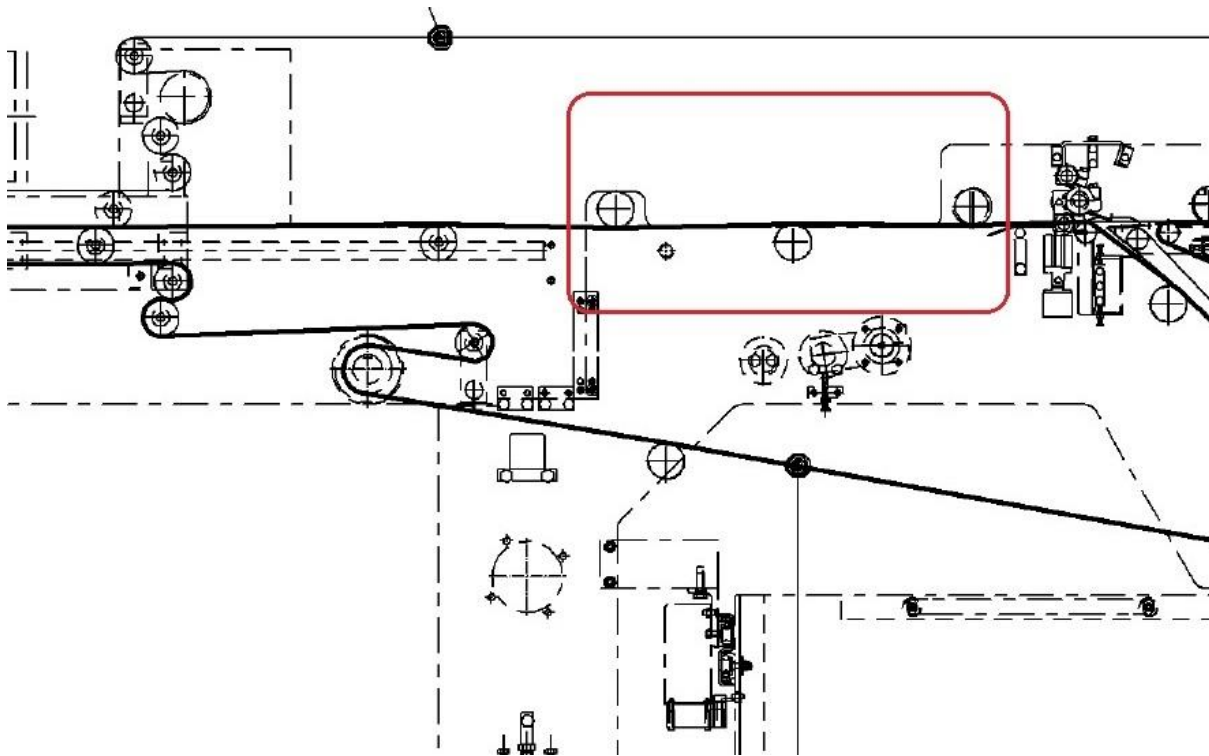

- a. Distance between rollers – 220 mm (approx.)
- b. Distance between support frames – 1500 mm (approx.)

Note: - The cleaning assembly shall be customised to meet the space available.

PROPOSED SYSTEM REQUIREMENT:

a. Cleaning Head Assembly

- i. Cleaning Heads should include modular brushes, web static control, blowing as well as vacuum suction of air.
- ii. Soft brushes are to be provided for boundary layer interruption. Brushes are to be of modular-type i.e., brushes shall be installed/ removed as per requirement of BNPM in the system. Material of the brushes should not cause creasing/ picking of paper fibers in the web. Surface inspection of paper web may be carried out by BNPM to check for creasing/picking of paper fibers after passing through cleaning head.
- iii. Static charge of the web is neutralized by use of suitable Anti-Static bars. Anti-static bars may be of AC/DC type. Suitable power supplies shall be provided by bidder for arranging supply as per anti-static bar type. Static control shall be provided at both entry and exit of the cleaning head.
- iv. Blowing and suction of air through designed profiles shall ensure removal of dust from surfaces of the web/ sheet.
- v. Cleaning head assembly shall be customized to meet the width requirements to ensure improved efficiency of web and sheet cleaning.

b. Blower/ Suction Fan Unit

- i. Blower/ suction fan unit/s shall be suitably sized to cater to the air flow, suction pressure requirements of the cleaning heads at Web as well as Sheet sections in the machine.

SECTION VII – TECHNICAL SPECIFICATIONS

- ii. Blower/ suction fan unit shall be enclosed inside suitable sound enclosure arrangement, if required, to maintain noise level <85 dB at one meter distance or lesser as per statutory requirement. Unit shall be of floor-mounting type with anti-vibration pads. No foundation pedestal/ masonry works shall be carried out.
- iii. Total power requirement of the complete installed units (i.e. entire Dust Collection System) shall preferably be under 10 kW plus 20% tolerance on higher side may be considered.
- iv. Motor shall be energy efficient (IE-4) motors having TEFC, IP-55 enclosure (including terminal boxes and bearing housing) with Class-F insulation confirming to IS 325. Values of motor efficiency shall be as per category 'EFF1' (or better) as given in IEEEMA Std. 19-2000 for all continuous duty motors. Motors with VVVF (Variable Voltage Variable Frequency) Drive shall be suitable for & compatible with VVVF (inverter duty) if any. The motor insulation shall be designed for PWM power.
- v. Bidder shall consider the available floor space of 1.2 meter x 1.5 meter while designing to accommodate filter unit.
- vi. If compressed air jet is required for blowing of air through cleaning heads, bidder shall provide necessary air compressor, compressor tank/bottle storage to meet the requirements. Bidder shall ensure the power requirement for compressor and vacuum fan be within the power requirement limit mentioned in point (ii) above.

c. Filter Unit

- i. The Filter unit should be rated of ePM1 75% or higher as per ISO 16890 or equivalent grade of filter standards. Necessary filter type test certificate shall be submitted by bidder.
- ii. The initial pressure drop and acceptable final pressure drop across filter unit should be provided by Bidder
- iii. Filter unit shall be provided with suitable purging system for cleaning of filter during stoppage of operations to increase life/ maintenance interval of filter. If manual cleaning of filters is necessitated, as per design, required quantity of filters shall be provided by vendor for 2 years of operation of unit.
- iv. Filter unit/ system should be provided with real time pressure drop indication.
- v. Filter unit should be enclosed inside suitable sound enclosure arrangement to maintain noise level <85 dB at one meter distance or lesser as per statutory requirement. Bidder may enclose both Blower and Filter unit inside suitable single sound enclosure. Unit shall be of floor-mounting type with anti-vibration pads. No foundation pedestal/ masonry works shall be carried out.

d. Ancillaries

- i. Necessary flexible and fixed ducting arrangement from cleaning heads to blower/filter unit shall be provided by bidder.
- ii. All required support structures and fabrications shall be carried out by bidder.
- iii. All tools and tackles required for erection and installation shall be brought by bidder.
- iv. All power cable supply, laying from feeder in the MCC room and necessary cable conduits shall be provided by bidder.
- v. All control supply and control cables laying shall be done by bidder.
- vi. All compressed air piping and pneumatic auxiliaries to be supplied by bidder.
- vii. Bidder shall submit all power and compressed air requirements in the bid.

Pre-Bid Visit:

It is a pre-requisite that, the bidder should visit the site prior to pre-bid meeting to understand the BNPM requirement as well as site conditions to participate in the tender. Intending bidders shall visit the site to

SECTION VII – TECHNICAL SPECIFICATIONS

understand the cabling and routing requirement before submitting the bid. The tender documents of the bidder, who did not visit the site prior to participation in the tender, shall be summarily rejected. Clause 13 – Specific Terms & Conditions of Contract of Section V – SCC may be referred for more details.

Commissioning:

After installation and testing, operation of the system for a period of continuous 48 hours as per operational shifts i.e., without any breakdown or interruption, attributable to the installed system, shall be considered as successful commissioning of the system. During this period, service engineer shall be available at site during General shift hours i.e., 0930 to 1800 hours.

Spares & Consumables:

1. Successful bidder should supply operational spares & consumables (viz. filters etc.), if replacement/manual cleaning (refer clause (c) (iii) – Filter Unit) is required as per operational design, needed for 2 (Two) years of operation along with equipment supply. Price list of operational spares & consumables are to be offered in FORM (B-2) provided in Section IX of tender.
2. Bidders shall furnish list of **recommended and essential spares** with price (as per FORM (B-3) & (B-4) provided in Section IX of tender) to be maintained for trouble-free operation of the system for a period of 2 (Two) years after completion of warranty period with the price validity for a minimum period of one year from the date of commissioning. BNPM reserves the right to exercise the option to procure the quoted items (partially/fully) from the successful bidder.

Further, supply of minimum spares & consumables required to maintain the system in smooth running condition during the warranty period shall be in the scope of bidder. Warranty spares shall include but not limited to the below items,

S No	Item Description	Quantity
1.	Modular brushes	01 Set
2.	Spare Filter (each type)	01 No

Documentation:

Successful bidder shall furnish two hard copy sets of manuals (containing GA drawings of the unit) for supplied hardware. Two hard copy sets of user manual with images for the supplied customized solution. Same shall be provided in an USB stick.

One set of all genuine installed application software with licenses and Editable Project software (for HMI and PLC) in an USB stick. Original software for HMI, PLC with single lifetime (perpetual) license shall be provided.

Facilities under BNPM Scope:

- i. BNPM will provide single point compressed air supply at 5.5 bar pressure.
- ii. BNPM will provide single point 3-phase, 4 wire, 415 V AC supply for rated current to the system. Bidder must carry out necessary cabling from point of supply, in power feeder at MCC room, to his system/panel.

(To be signed & stamped and submitted along with Techno-commercial Bid Part –I)

SECTION VIII – QUALITY CONTROL REQUIREMENTS

We shall supply the material strictly as per specifications and compliance statements given below.

Technical Compliance Statement:

S No	Compliance Parameter	Offered by bidder	Deviation, if any
1.	We have read and understood the system requirement for dust cleaning solution as provided in Section VII of the tender.	<input type="checkbox"/> YES / <input type="checkbox"/> NO	
2.	We agree that, the proposed system shall be in compliance to the requirements provided in Section VII of the tender.	<input type="checkbox"/> YES / <input type="checkbox"/> NO	
3.	We understand and agree that, following shall be in bidder's scope, i. Supply of hardware of the system. ii. Erection & installation of hardware, electrical & electronics and components of support structure. iii. All necessary power boards, cables, flexible hoses and ducts with required length including cabling from power feeder in the MCC room at BNPM. iv. Panels for housing the Electricals, Electronics and Wiring.	<input type="checkbox"/> YES / <input type="checkbox"/> NO	
4.	We agree to design, supply, install, commission and train BNPM representatives on the solution/system proposed by us as per proposed system requirement.	<input type="checkbox"/> YES / <input type="checkbox"/> NO	
5.	We agree that, the proposed solution/system will be suitable for installation at the machine location as indicated in Section VII of the tender.	<input type="checkbox"/> YES / <input type="checkbox"/> NO	
6.	We undertake that, we have visited BNPM to understand the understand the BNPM requirement as well as site conditions to participate in the tender.	Date of visit: _____	
7.	We understand and agree that, successful commissioning shall mean operation of the system for a period of continuous 48 hours as per operational shifts (i.e. without any breakdown or interruption attributable to installed system) after installation and testing.	<input type="checkbox"/> YES / <input type="checkbox"/> NO	
8.	We agree to deliver list of operational spares & consumables as listed in Form B-2 along with the delivery of equipment as per quoted cost.	<input type="checkbox"/> YES / <input type="checkbox"/> NO	
9.	We confirm that, list of mandatory and essential spares required for trouble free operation of the system for 2 years period as per operational design has been provided in Section IX – Form B-3 & B-4.	<input type="checkbox"/> YES / <input type="checkbox"/> NO	
10.	We confirm to keep the price of mandatory and essential spares & consumables for a period of 1 year from the date of successful commissioning.	<input type="checkbox"/> YES / <input type="checkbox"/> NO	
11.	We understand and agree that, BNPM reserves the right to exercise the option to procure the mandatory &	<input type="checkbox"/> YES / <input type="checkbox"/> NO	

SECTION VIII – QUALITY CONTROL REQUIREMENTS

	essential spares and consumables (partially/fully) from the successful bidder at the quoted cost.		
12.	We agree to furnish two hard copy sets of manuals (containing GA drawings of the unit) for supplied hardware along with soft copy in an USB stick.	<input type="checkbox"/> YES / <input type="checkbox"/> NO	
13.	We agree to provide one set of all genuine installed application software with perpetual licenses and editable project software in an USB stick.	<input type="checkbox"/> YES / <input type="checkbox"/> NO	
14.	We understand and agree that, only following facilities shall be provided by BNPM, i. Single point compressed air supply at 5.5 bar pressure. ii. Single point 3-phase, 4 wire, 415 V AC supply for rated current to the system. Bidder must carry out necessary cabling from point of supply, in power feeder at MCC room, to his system/panel.	<input type="checkbox"/> YES / <input type="checkbox"/> NO	

* Bidder has to fill:

YES – In case compliance remains exactly same as per compliance parameter.

NO – In case offered solution does not match with the compliance parameter and deviation is to be provided below at the designated place.

(Acceptance to deviations shall be at sole discretion of BNPM. In case of non-acceptance of deviations, bid is liable to be rejected. Interested bidders may get pre-clarifications to technical deviations from BNPM prior to submission of bid to avoid rejection of bids at a later stage)

(To be signed & stamped and submitted along with Techno-commercial Bid Part –I)

COMMERCIAL COMPLIANCE STATEMENT

Sl. no.	Features	Requirements of BNPMIPL, Terms & conditions	Whether Agreed by the firm	Deviation, if any
01	General Conditions for supply	Supply & service shall be rendered exactly as per the instructions mentioned in the Section VI & VII.	Yes agreed	
02	Technical Specifications	As per the scope of work provided in Section VII under Technical Specifications.	Yes agreed	
03	Quantity	As indicated in Section VI - List of Requirement.	Yes agreed	
04	Delivery	As indicated in Section VI - List of Requirement.	Yes agreed	
05	Payment terms	Payment terms as mentioned in Clause 8 of SCC.	Yes agreed	
06	Liquidated Damages	As per liquidated damages clause mentioned in the tender.	Yes agreed	
07	Performance security	As per performance security clause mentioned in the tender. (SCC Clause: 2)	Yes agreed	
08	Warranty	As per warranty clause mentioned in the tender. (SCC Clause: 4)	Yes agreed	
09	Tender terms & conditions	We have gone through entire tender document thoroughly including GIT (Section II - General Instructions to Tenderer), GCC (Section IV - GENERAL CONDITIONS OF CONTRACT) <u>and confirm that we don't have any counter conditions.</u> We also understand that offer with counter conditions is liable for rejection.	Yes agreed	
10	Compliance to SIT & SCC clauses	SIT Clause: Sl.no. 1 to Sl.no. 21 SCC Clause: Sl.no. 1 to Sl.no. 26	Yes agreed	
11	No. of pages	Total number of pages in Technical Bid		

Authorized signatory & stamp

(To be signed & stamped and submitted along with Techno-commercial Bid Part -I)

SECTION IX – QUALIFICATION/ ELIGIBILITY CRITERIA

Category	Eligibility Criteria	Documents required in support of eligibility criteria
General	<p>a) Bidder* (Individual/ firm/ company/ corporate / LLP / HUF / limited company) intending to bid should be bonafide, experienced, technically competent, resourceful and financially sound to carry out the assigned order.</p> <p>*Any bidder from a country which shares a land border with India will be eligible to bid in the tender only if the bidder is registered with the Competent Authority (The Registered Committee constituted by the Department for Promotion of Industry and Internal Trade).</p>	<p>Company's registration / Certificate of incorporation with MOA & AOA /Partnership Deed/Any other registration certificate as applicable</p> <p>Signed & Stamped Annexure - A on company's letter head.</p>
	b) Bidder should have valid GST registration certificate.	Copy of GST certificate
	c) Bidder should have valid PAN card.	Copy of PAN card
	d) As on the date of submission of bid against this tender, bidder should not be in the list of ineligible/ blacklisted/ banned/ debarred entity by SPMCIL/ BRBNMPL/ BNPMIPL/any Government Agency for participating in its tenders.	Declaration as per Annexure-B on company's letter head duly Signed & with company Stamp to be submitted
Experience & Past Performance	<p>a) Bidder should have successfully supplied, installed & commissioned at least 1 No of Web Dust Cleaning System with electrostatic control to any Paper/ Film/ Foil Industry in any 1 (One) year of last 5 (Five) years ending 28.02.2025.</p> <p>b) For Start-up bidders: Criteria is exempted for Start-ups recognized by DPIIT and having capability to execute the supply as per the quality & technical specifications specified in the tender.</p>	<p>The bidder shall submit copy of signed:</p> <p>i. Purchase order / Work order / Agreement / Contract.</p> <p>ii. Tax Invoice.</p> <p>iii. Documents evidencing successful supply, installation & commissioning (viz. LR/E-way bill/GSTR etc.).</p> <p>Note:</p> <p>e) BNPM reserves the right to seek additional documents related to the documents submitted against eligibility criteria.</p> <p>f) The start-ups should be recognized by DPIIT and certificate of recognition issued by DPIIT clearly stating the "sector" & "industry" corresponding to item in the tender should be submitted along with the bid. In case of unavailability of corresponding sector / industry in the certificate, bidder should submit documents</p>

SECTION IX – QUALIFICATION/ ELIGIBILITY CRITERIA

		approved/ accepted by DPIIT substantiating relevance to the item in the tender.
	c) The bidder should be a manufacturer (or) authorized dealer / distributor / partner / representative of the manufacturer of the offered solution.	Self-declaration duly signed by bid signatory in case of manufacturer. (or) Filled & signed Manufacturer's authorization form (MAF) ^[Ref Note (iv)] issued by Manufacturer as provided in Section XIV in case of authorized dealer / distributor / partner / representative.
	d) Bidder participating as Authorized Representatives should have been associated with same (or) other principal manufacturers for same set of services as present in tender (i.e. Supply, Installation, satisfactory Commissioning, after sales services as the case may be) for same (or) similar product for past 3 years ending 28.02.2025.	Declaration from associated principal manufacturer regarding bidder's association for past 3 years pertaining to same set of services.
Financial Standing	a) Average annual turnover of the bidder firm during last three financial year's period ending 31.03.2024 should be more than Rs. 25,50,000/- (Rupees Twenty-Five Lakh Fifty Thousand only) .	Audited balance sheet and profit & loss statement for FY: 2023-24, FY: 2022-23, FY: 2021-22 and FY: 2020-21. Chartered Accountants certificate for Turnover, Profit and Net worth may be accepted for the bidders, where tax audits has been exempted as per the existing Govt. orders issued before tender closing date. Note: The start-ups should submit certificate of recognition issued by DPIIT.
	b) For start-up bidders: Turnover criteria is relaxed for Start-ups recognized by DPIIT. Such start-ups are required to have an average annual turnover of at-least Rs. 19,12,500/- (Rupees Nineteen Lakh Twelve Thousand Five Hundred only) during last three financial year's period ending 31.03.2024.	
	c) Net worth of the bidder firm should not be in negative as on 31.03.2024 and should have not eroded ^[Ref Note (ii)] by more than 30% (Thirty percent) year-on-year basis as well as cumulative basis in the last three financial year's period ending 31.03.2024.	
Note:		
i. If the date of constitution/ incorporation of the bidder's firm is less than three financial years, then the average annual financial turnover during the last two years/ last financial year (as the case may be) should be at least as mentioned in clause (a) of Financial Standings mentioned above.		
ii. Erosion shall be calculated only on account of reported loss in the statement of P&L account, which has led to reduction in		

SECTION IX – QUALIFICATION/ ELIGIBILITY CRITERIA

capital. Net-worth (NW) erosion will be calculated as below,

Year - on - Year basis	Cumulative basis
$\frac{\text{(NW of FY 2023-24 (-) NW of FY 2022-23)}}{\text{(NW of FY 2022-23)}}$	$\frac{\text{(NW of FY 2023 - 24 (-) NW of FY 2020 - 21)}}{\text{(NW of FY 2020 - 21)}}$
$\frac{\text{(NW of FY 2022-23 (-) NW of FY 2021-22)}}{\text{(NW of FY 2021-22)}}$	
$\frac{\text{(NW of FY 2021-22 (-) NW of FY 2020-21)}}{\text{(NW of FY 2020-21)}}$	

- iii. BNPM reserves the right to verify all credentials submitted by bidders towards eligibility criteria.
- iv. 1 Manufacturer can authorize only one authorized dealer / distributor / partner / representative as per MAF.
- v. **Bidders participating as authorized representatives, who are exclusively appointed by the principal manufacturer to represent them in India will also be eligible to apply or take part in the bid provided principal manufacturer meets "Experience & Past Performance" & "Financial Standing" criteria's without exemption.**
- vi. Consortiums/JVs are not allowed to participate in this tender.

- I) *Any bidder from a country which shares a land border with India will be eligible to bid in the tender only if the bidder is registered with the Competent Authority (The Registered Committee constituted by the Department for Promotion of Industry and Internal Trade).
- II) Bidder means any person or firm or company, including any member of a consortium or joint venture (that is an association of several persons, or firms, or companies), every artificial judicial person not falling in any of the descriptions of bidders stated hereinbefore, including any agency branch or office controlled by such person participating in a procurement process.
- III) "Bidder from a country which shares a land border with India" for the purpose of this order means:-
 - a) An entity incorporated, established or registered in such a country; or
 - b) A subsidiary controlled through entities incorporated, established or registered in such a country, or
 - c) An entity substantially controlled through entities incorporated, established or registered in such a country, or
 - d) An entity whose beneficial owner is situated in such a country; or
 - e) An India (or other) agent of such an entity; or
 - f) A natural person who is a citizen of such a country; or
 - g) A consortium or joint venture where any member of the consortium or joint venture falls under any of the above.
- IV) The beneficial owner for the purpose of (iii) above will be as under:-
 - 1) In case of a company or limited liability partnership, the beneficial owner is the natural person (s), who, whether acting alone or together, or through one or more judicial person, has a controlling ownership interest or who exercise control through other means.

Further explanation:

- a) "Controlling ownership interest" means ownership of or entitlement to more than twenty five per cent of shares or capital or profits of the company;
- b) "Control" shall include the right to appoint majority of the director or to control the management or policy decision including by virtue of their shareholding or management rights or shareholder agreements or voting agreements;

SECTION IX – QUALIFICATION/ ELIGIBILITY CRITERIA

- 2) In case of partnership firm, the beneficial owner is the natural person(s) who, whether acting alone or together, or through one or more judicial person, has ownership of entitlement to more than fifteen percent of capital or profits of the partnership;
- 3) In case of an unincorporated association or body of individuals, the beneficial owner is the natural person(s), who , whether acting alone or together, or through one or more judicial person, has ownership of or entitlement to more than fifteen percent of the property or capital or profits of such association or body of individuals;
- 4) Where no natural person is identified under (1) or (2) or (3) above, the beneficial owner is the relevant natural person who holds the position of senior managing official;
- 5) In case of a trust, the identification of beneficial owners(s) shall include identification of the author of the trust, the trustee, the beneficiaries with fifteen percent or more interest in the trust and any other natural person exercising ultimate effective control over the trust through a chain of control or ownership.

- V) An agent is a person employed to do any act for any another, or to represent another in dealings with third persons.
- VI) The successful bidder shall not be allowed to sub contract works to any contractor from a country which shares a land border with India unless such contractor is registered with the Competent Authority.
- VII) A bidder is permitted to procure raw material, components, sub-assemblies etc. from the vendors from countries which shares a land border with India. Such vendors will not be required to be registered with the competent authority, as it is not regarded as sub-contracting.
- VIII) However, in case a bidder has proposed to supply finished goods procured directly/indirectly from the vendors from the countries sharing land border with India, such vendor will be required to be registered with the competent authority.
- IX) The registration shall be valid at the time of submission of bid and at the time of acceptance of bid.

 Bidder to furnish stipulated documents in support of fulfillment of qualifying criteria. Non-submission or incomplete submission of documents may lead to rejection of offer.

All experience, past performance and capacity/ capability related/ data should be certified by the authorized signatory of the bidder firm. The credentials regarding experience and past performance to the extent required as per eligibility criteria submitted by bidder may be verified from the parties for whom work has been done.

We confirm that, we are competent and legally authorized to submit the tender and / or to enter into legally binding contract. We (Name of the company) have submitted the required documents in support of the eligibility criteria mentioned above.

Authorized Signature with stamp & date

(To be signed & stamped and submitted along with Techno-commercial Bid Part -I)



SECTION IX – QUALIFICATION/ ELIGIBILITY CRITERIA

ANNEXURE – A

e-Tender No: BNPM/NCB/565/2024-25 dated 12.03.2025.

(To be submitted on Company letterhead)

DECLARATION

I have read the clause regarding restrictions on procurement from a bidder of a country which shares a land border with India. I hereby certify that M/s is not from such a country or, if from such a country, has been registered with the Competent Authority. I hereby certify that M/s fulfills all requirements in this regard and is eligible to be considered.” (Where applicable, evidence of valid registration by the Competent Authority shall be attached)

I, the undersigned, declare that the item originate in (Name of the country).

Signature _____

Name-----

Designation-----

Date-----

Stamp of the Organization-----



SECTION IX - QUALIFICATION/ ELIGIBILITY CRITERIA

ANNEXURE - B

e-Tender No: BNPM/NCB/565/2024-25 dated 12.03.2025.

(To be submitted on Company letterhead)

DECLARATION

I) We do hereby declare that,

1. As on the date of submission of bid against this tender we are not in the list of ineligible/ blacklisted/ banned/ debarred entity by SPMCIL/ BRBNMPL/ BNPMIPL/any Government Agency, for participating in its tenders.

Further, we agree, in case we got blacklisted/ banned/ debarred by SPMCIL/ BRBNMPL/ BNPMIPL/any Government Agency, any time prior to finalization of tender/ contract, our bid shall not be considered for further evaluation/ award of order.

2. The director/proprietor of the bidding firm are not closely related to BNPMIPL.

In case, at any time the information furnished is found to be false, you may disqualify/ debar me/ us as deemed fit.

II) We do hereby declare that we have read and understood all terms and conditions of tender document including GIT, SIT, GCC, SCC, Technical Specification, Quality Control Criteria and confirm to abide to those conditions without any counter conditions.

Signature _____

Name-----

Designation-----

Date-----

Stamp of the Organization-----



SECTION IX – QUALIFICATION/ ELIGIBILITY CRITERIA

ANNEXURE – C

e-Tender No: BNPM/NCB/565/2024-25 dated 12.03.2025.

(To be submitted on Company letterhead)

DECLARATION

Table 1: Past Experience Details

Sl. No.	Description of Supply/Work	Name & Address of Customer	PO/WO/ /Agreement No. with date	Qty. of Supply / Services provided	Completion Period (MM/YYYY)
1					

Table 2: Bidders claiming relaxation under Start-up provisions:

1	Whether exemption claimed under provisions of Start-up?	<input type="checkbox"/> YES / <input type="checkbox"/> NO
2	If yes, whether Start-up is recognized by DPIIT?	DPIIT certificate no: _____
3	If recognized by DPIIT, whether documents approved/ accepted by DPIIT substantiating relevance to the service in the tender is available & enclosed to the bid?	<input type="checkbox"/> YES / <input type="checkbox"/> NO

Table 3: Financial Details

Sl. No.	Financial Year	Annual Turn Over (Rs.)	Networth (Rs.)	UDIN Particulars
1	2023-24			
2	2022-23			
3	2021-22			
4	2020-21			

Table 4:

Please tick as applicable	<input type="checkbox"/> Manufacturer.
	<input type="checkbox"/> Authorized dealer / distributor / partner / representative.
Document submitted in support of the above	<input type="checkbox"/> Self – Declaration (only for manufacturers).
	<input type="checkbox"/> MAF as per Section XIV issued by manufacturer.

Signature _____

Name-----

Designation-----

Date-----

Stamp of the Organization-----

SECTION IX – QUALIFICATION/ ELIGIBILITY CRITERIA

ANNEXURE – D

e-Tender No: BNPM/NCB/565/2024-25 dated 12.03.2025.

(To be submitted on Company letterhead)

BID SECURITY DECLARATION

We, the undersigned, declare that we will automatically be suspended from being eligible for bidding in any tender with Bank Paper Mill India Private Limited, Mysuru for the period of 12 months, if we are withdrawing our Bid during the period of bid validity (or) fail / refuse to furnish the performance security / execute the contract, if awarded.

Signature _____

Name-----

Designation-----

Date-----

Stamp of the Organization-----



SECTION IX - QUALIFICATION/ ELIGIBILITY CRITERIA

ANNEXURE - E

e-Tender No: BNPM/NCB/565/2024-25 dated 12.03.2025.

(To be submitted on Company letterhead)

DECLARATION UNDER PREFERENCE TO MAKE IN INDIA POLICY

In line with Government Public Procurement Order No. P-45021/2/2017-BE-II dt. 15.06.2017 and as amended from time to time and as applicable on the date of submission of tender, we hereby certify that we, M/s _____ (supplier name) are local supplier meeting the requirement of minimum Local content as per details below for the material against Tender No _____

1. We declare to be (Tick one)

- | | |
|---|--------------------------|
| a. Class-I Supplier (50% or more local content) | <input type="checkbox"/> |
| b. Class-II Supplier (20% to 50% local content) | <input type="checkbox"/> |
| c. Non-Local Supplier (Less than 20% local content) | <input type="checkbox"/> |

2. Details of location at which local value addition will be made is as follows:

S No	Name of the Item	Name of Manufacturer	Country of Origin	% Value to the total cost	Location (s) and address at which the local value addition is made

We also understand, false declarations will be in breach of the Code of Integrity under Rule 175(1)(i)(h) of the General Financial Rule for which for which a bidder or its successors can be debarred for up two years as per Rule 151 (iii) of the General Financial Rules along with such other actions as may be permissible under law.

BNPM reserves the right to verify the local content in terms of the requirement of Public Procurement (Preference to Make in India) Order.

Signature _____

Name-----

Designation-----

Date-----

Stamp of the Organization-----

SECTION X- TENDER FORM

(Bidder shall use this covering letter while submitting the offer)

To

Date _____

Bank Note Paper Mill India Private Limited
Administrative Building
Entry Gate No 1, Paper Mill Compound,
Note Mudran Nagar
Mysuru 570 003
Karnataka

Ref: Your Tender document No.....dated.....

We, the undersigned have examined the above mentioned tender enquiry document, including amendment No. -----, dated ----- (if any), the receipt of which is hereby confirmed. We now offer to supply and deliver..... (description of goods and services) in conformity with your above referred document for the sum as shown in the price schedule(s), attached herewith and made part of this tender.

If our tender is accepted, we undertake to supply the goods and perform the services as mentioned above, in accordance with the delivery schedule specified in the List of Requirements.

We further confirm that, if our tender is accepted, we shall provide you with a performance security of required amount in an acceptable form in terms of GCC clause 6, read with modification, if any, in Section V- "Special Conditions of Contract", for due performance of the contract.

We agree to keep our tender valid for acceptance for a period up to **120 days**, as required in the GIT clause 19, read with modification, if any in Section-III -"Special Instructions to Tenderers" or for subsequently extended period, if any, agreed to by us. We also accordingly confirm to abide by this tender up to the aforesaid period and this tender may be accepted any time before the expiry of the aforesaid period. We further confirm that, until a formal contract is executed, this tender read with your written acceptance thereof within the aforesaid period shall constitute a binding contract between us.

We further understand that you are not bound to accept the lowest or any tender you may receive against your above-referred tender enquiry.

(Signature with date)

(Name and designation)

Duly authorised to sign tender for and on behalf of

SECTION XI - PRICE SCHEDULE

(TO BE FILLED ONLINE ONLY THROUGH E-PORTAL)

(A copy of sealed & signed blank price schedule has to be submitted along with pre-qualification & techno-commercial offer)

Dear Sir,

SUB: PRICE BID FOR DESIGN, SUPPLY, INSTALLATION, TESTING AND COMMISSIONING OF DUST CLEANING SOLUTION FOR SHEETER MACHINE AT BNPM PLANT, MYSURU.

Ref: e-Tender No: BNPM/NCB/565/2024-25 dated 12.03.2025.

FORM B-1

We have received and understood the above tender enquiry and are pleased to submit our price bid as under:

Sch edu le No.	Description	UOM	Quantity	HSN /SAC Code	Price for Supply & Service (INR)								
					Basic unit Price (INR)	Freight, P&F, Transit Insuranc e & any other charges (INR)	Unit price (Incl. of Freight, P&F, Transit Insurance & any other charges) (INR)	GST @ —%	GST Amount (INR)	Total unit price (Incl. of Freight, P&F, Transit Insurance, any other charges & GST) (INR)	Input Tax Credit for HSN/ SAC (INR)	Effective unit price (Incl. of Freight, P&F, Transit Insurance, any other charges) (INR)	Total Effective price (Incl. of Freight, P&F, Transit Insurance, any other charges) (INR)
					(b)	(c)	(d)=(b)+(c)	(%)	(e) = (d)*(%)	(f)=(d)+(e)	(g)	(h)=(f)-(g)	(i)=(h)*(a)
1.	Design, Supply, Installation, Testing & Commissioning of Dust Cleaning Solution for Sheeter Machine at BNPM, Mysuru.	LS	1		TO BE FILLED ONLINE IN E-TENDERING PORTAL ONLY								



SECTION XI - PRICE SCHEDULE

(TO BE FILLED ONLINE ONLY THROUGH E-PORTAL)

(A copy of sealed & signed blank price schedule has to be submitted along with pre-qualification & techno-commercial offer)

Dear Sir,

SUB: PRICE BID FOR SUPPLY OF OPERATIONAL SPARES & CONSUMABLES FOR DUST CLEANING SOLUTION AT BNPM PLANT, MYSURU.

Ref: e-Tender No: BNPM/NCB/565/2024-25 dated 12.03.2025.

FORM B-2

We have received and understood the above tender enquiry and are pleased to submit our price bid as under:

Sch edu le No.	Description	UOM	Quantity	HSN Code	Price for Supply (INR)								
					Basic unit Price (INR)	Freight, P&F, Transit Insuranc & any other charges (INR)	Unit price (Incl. of Freight, P&F, Transit Insurance & any other charges) (INR)	GST @ _%	GST Amount (INR)	Total unit price (Incl. of Freight, P&F, Transit Insurance, any other charges & GST) (INR)	Input Tax Credit for HSN/ SAC (INR)	Effective unit price (Incl. of Freight, P&F, Transit Insurance, any other charges) (INR)	Total Effective price (Incl. of Freight, P&F, Transit Insurance, any other charges) (INR)
			(a)		(b)	(c)	(d)=(b)+(c)	(%)	(e) = (d)*(%)	(f)=(d)+(e)	(g)	(h)=(f)-(g)	(i)=(h)*(a)
1.	Modular Brushes	Set	1		TO BE FILLED ONLINE IN E-TENDERING PORTAL ONLY								
2.	Spare Filter (each type)	No	1										
3.													
4.													
Total effective price (net of input tax credit) for 2 years operational spares and consumables at BNPM, Mysuru [in Figures]													
(INR) $\sum_{1+2+3+\dots+n}$													
Total effective price (net of input tax credit) for 2 years operational spares and consumables at BNPM, Mysuru [in Words]													
(INR) $\sum_{1+2+3+\dots+n}$													



SECTION XI – PRICE SCHEDULE

(TO BE FILLED ONLINE ONLY THROUGH E-PORTAL)

Dear Sir,

SUB: PRICE BID FOR RECOMMENDED SPARES & CONSUMABLES OF DUST CLEANING SOLUTION FOR SHEETER MACHINE AT BNPM PLANT, MYSURU.

Ref: e-Tender No: BNPM/NCB/565/2024-25 dated 12.03.2025.

FORM B-3

We have received and understood the above tender enquiry and are pleased to submit our price bid for mandatory spares & consumables as under:

Sch edu le No.	Description	UOM	Quantity	HSN /SAC Code	Price for Supply (INR)								
					Basic unit Price (INR)	Freight, P&F, Transit Insuranc & any other charges (INR)	Unit price (Incl. of Freight, P&F, Transit Insurance & any other charges) (INR)	GST @ _%	GST Amount (INR)	Total unit price (Incl. of Freight, P&F, Transit Insurance, any other charges & GST) (INR)	Input Tax Credit for HSN/ SAC (INR)	Effective unit price (Incl. of Freight, P&F, Transit Insurance, any other charges) (INR)	Total Effective price (Incl. of Freight, P&F, Transit Insurance, any other charges) (INR)
			(a)		(b)	(c)	(d)=(b)+(c)	(%)	(e) = (d)*(%)	(f)=(d)+(e)	(g)	(h)=(f)-(g)	(i)=(h)*(a)
1.					TO BE FILLED ONLINE IN E-TENDERING PORTAL ONLY								
2.													
3.													
4.													
5.													
6.													

VALIDITY OF THE OFFERED PRICE: 1 YEAR FROM THE DATE OF COMMISSIONING OF EQUIPMENT AT BNPM, MYSURU.

(A copy of sealed & signed blank price schedule filled with list of spares with quantity has to be submitted along with techno-commercial bid Part - I)



SECTION XI – PRICE SCHEDULE

(TO BE FILLED ONLINE ONLY THROUGH E-PORTAL)

Dear Sir,

SUB: PRICE BID FOR ESSENTIAL SPARES & CONSUMABLES OF DUST CLEANING SOLUTION FOR SHEETER MACHINE AT BNPM PLANT, MYSURU.

Ref: e-Tender No: BNPM/NCB/565/2024-25 dated 12.03.2025.

FORM B-4

We have received and understood the above tender enquiry and are pleased to submit our price bid for essential spares & consumables as under:

Sch edu le No.	Description	UOM	Quantity	HSN /SAC Code	Price for Supply (INR)								
					Basic unit Price (INR)	Freight, P&F, Transit Insuranc & any other charges (INR)	Unit price (Incl. of Freight, P&F, Transit Insurance & any other charges) (INR)	GST @ _%	GST Amount (INR)	Total unit price (Incl. of Freight, P&F, Transit Insurance, any other charges & GST) (INR)	Input Tax Credit for HSN/ SAC (INR)	Effective unit price (Incl. of Freight, P&F, Transit Insurance, any other charges) (INR)	Total Effective price (Incl. of Freight, P&F, Transit Insurance, any other charges) (INR)
			(a)		(b)	(c)	(d)=(b)+(c)	(%)	(e) = (d)*(%)	(f)=(d)+(e)	(g)	(h)=(f)-(g)	(i)=(h)*(a)
1.					TO BE FILLED ONLINE IN E-TENDERING PORTAL ONLY								
2.													
3.													
4.													
5.													
6.													

VALIDITY OF THE OFFERED PRICE: 1 YEAR FROM THE DATE OF COMMISSIONING OF EQUIPMENT AT BNPM, MYSURU.

(A copy of sealed & signed blank price schedule filled with list of spares with quantity has to be submitted along with techno-commercial bid Part - I)



SECTION XII – QUESTIONNAIRE

The tenderer should furnish specific answers to all the questions/ issues mentioned below. In case a question/ issue does not apply to a tenderer, the same should be answered with the remark “not applicable”.

Wherever necessary and applicable, the tenderer shall enclose certified copy as documentary proof/ evidence to substantiate the corresponding statement.

In case a tenderer furnishes a wrong or evasive answer against any of the under mentioned question/ issues, its tender will be liable to be ignored.

S. No.	Description	To be filled by bidder
1	Brief description of goods and services offered	
2	Offer is valid for acceptance up to	120 Days
3	Your permanent income tax A/c no. as allotted by the Income Tax Authority of Government of India	
4	Are you currently registered with the Directorate General of Supplies & Disposals (DGS&D), New Delhi, and/ or the present BNPMIPL and/ or the Directorate of Industries of the concerned State Government/NSIC/SSI for the goods quoted? If so, indicate the date up to which you are registered and whether there is any monetary limit imposed on your registration.	Yes / No If Yes: Registration No..... Validity:
5	Are you currently registered under the Indian Companies Act, 1956 or any other similar Act? (Please attach certified copy (s) of your registration status etc. in case your answer (s) to above queries is in affirmative	
6	Bank account/NEFT/RTGS details	Name of bank: Branch: A/c No.: IFSC: MICR:
7	Please state whether business dealings with you currently stand suspended/ banned by any Ministry/ Dept. of Government of India or by any State Govt.	

SECTION XII – QUESTIONNAIRE

8	EMD details:	Online / Offline / Exempted/Not Applicable
	a) Online:	NEFT/RTGS Details: _____ Dtd: _____
	b) Offline	DD / BG No. _____ Dtd: _____
	c) Exempted:	Whether NSIC/MSE/DGS&D Reg. no: _____
9	Tender Fee:	Online / Offline
	a) Online:	NEFT/RTGS Details: _____ Dtd: _____
	b) Offline:	DD No. _____ Dtd: _____
10	We confirm that we possess the necessary technical competence and financial resources as mentioned in Section -IX of this tender document, to ensure supply of the tendered item, as per your specifications and delivery schedule. Necessary documents like copies of Work orders, P/L Accounts, Balance Sheets are enclosed	Yes / No
11	We confirm that we have quoted exactly for the tendered product as per your specifications given in Section VII	Yes / No
12	We confirm that the Price bid is quoted exactly as per your format in Section- XI	Yes / No
13	We confirm that there would not be any price escalation (Except Statutory Charges) during the supply / contract period	Yes / No
14	We confirm that we will abide by all the tender terms & conditions and we do not have any counter conditions. As required, we enclose herewith the complete set of copy of tender documents duly signed by us as a token of our acceptance	Yes / No

We also confirm that the undersigned is duly authorized and have the competence to submit the tender and / or to enter into legally binding contract for and on behalf of the firm.

.....

(Signature with date)

(Full name, Designation & address of the person duly authorized sign on behalf of the tenderer)

For and on behalf of

.....

.....

(Name, address and stamp of the tendering firm)

SECTION XIII- BANK GUARANTEE FORM FOR EMD

..... (Insert: Bank's Name, and Address of Issuing Branch or Office)

Beneficiary:

Bank Note Paper Mill India Private Limited
Administrative Building,
Paper Mill Compound, Note Mudran Nagar,
Mysuru- 570003, Karnataka, India
Date:.....

Bank Guarantee No:.....

Whereas.....(hereafter Called the "Tenderer") has submitted its quotation dated.....for the supply of..... (hereinafter called the "tender") against Bank Note Paper Mill India Private Limited's tender enquiry No.....Know all persons by these presents that we.....of (hereinafter called the "Bank") having our registered office at.....

Are bound unto Bank Note Paper Mill India Private Limited (hereinafter called the "BNPMIPL") in the sum of for which payment will and truly to be made to the said BNPMIPL, the Bank binds itself, its successors and assigns by these presents.

Sealed with the Seal of the said Bank this.....day of.....20.....

The conditions of this obligation are -

- 1) If the Tenderer withdraws or amends, impairs or derogates from the tender in any respect within the period of validity of this tender.
- 2) If the tenderer having been notified of the acceptance of his tender by BNPMIPL during the period of its validity:-
 - a) Fails or refuses to furnish the performance security for the due performance of the contract.
 - b) Fails or refuses to accept/ execute the contract.

We undertake to pay Bank Note Paper Mill India Private Limited up to the above amount upon receipt of its first written demand, without Bank Note Paper Mill India Private Limited having to substantiate its demand, provided that in its demand BNPMIPL will note that the amount claimed by it is due to it owing to the occurrence of one or both the two conditions, specifying the occurred condition (s).

This guarantee will remain in force for a period of forty five days after the period of tender validity and any demand in respect thereof should reach the Bank not later than the above date.

.....
Signature of the authorized officer of the Bank)

.....
Name, authorization/ signature no. and designation of the officer
Seal, Name & Address of the Bank and Address of the Branch



SECTION XIII- BANK GUARANTEE FORM FOR EMD

Checklist for Bank Guarantee:

EMD BG should be in line with / comply the following.

1. BG should be issued on not less than Rs. 300/- e-stamp / non-judicial stamp paper in case of paper Bank Guarantees (or) not less than Rs. 200/- e-stamp in case of e-Bank Guarantees.
2. Non judicial stamp paper / e-stamp paper should be purchased in the name of BG issuing bank only.
3. In case of stamp/e-stamp paper first party should be BG issuing bank and second party should be BNPM.
4. Date of sale of non-judicial / e stamp paper shown on the BG and the stamp paper (BG) issued is not more than six months prior to the date of execution of BG.
5. Executing officer of BG should indicate his name, designation and power of attorney number / signing power no etc. on each page of BG.
6. Name and address of the supplier, name and address of BNPM and value are to be mentioned clearly.
7. Overwriting / cutting if any in BG should be authenticated under signature and seal of authorized signatory of BG issuing Bank.
8. BG number and BG date should be mentioned in all pages of BG and all pages are endorsed / signed by authorized signatories of issuing bank.
9. Amount mentioned in figures and words are to be matched.
10. Validity of BG should be in line with clause (18.5) of Section II – General Instructions to Tenderers.
11. BG should be unconditional.
12. Our Bank details is mentioned below:

Name of the Bank: **HDFC Bank.**

Name of the Branch: **Richmond Road Branch.**

Account No: **05230350002465.**

Branch Address: **No. 8/24, Salco Centre, Bangalore- 560025, Karnataka.**

IFSC: **HDFC0000523.**

SECTION XIV- MANUFACTURER'S AUTHORIZATION FORM

To
Bank Note Paper Mill India Private Limited
Administrative Building, Entry Gate 1,
Paper Mill Compound, Note Mudran Nagar,
Mysore - 570003. Karnataka.

Dear Sirs,

Ref. Your Tender document no. _____ dated _____

We, _____ who are proven and reputable manufacturers of _____ (name and description of the goods offered in the tender) having factories at _____ hereby authorize Messrs. _____ (name and address of the agent) to submit a tender, process the same further and enter into a contract with you against your requirement as contained in the above referred tender enquiry documents for the above goods manufactured by us.

We further confirm that no supplier or firm or individual other than Messrs. _____ (name and address of the above agent) is authorized to submit a tender, process the same further and enter into a contract with you against your requirement as contained in the above referred tender enquiry documents for the above goods manufactured by us.

We also hereby extend our full warranty, as applicable as per clause 16 of the General Conditions of Contract read with modification, if any, in the Special Conditions of Contract for the goods and services offered for supply by the above firm against this tender document.

Yours faithfully,

[Signature with date, name and designation]

For and on behalf of Messrs.

.....

[Name & address of the manufacturers]

Note: This letter of authorization should be on the letter head of the manufacturing firm and should be signed by a person competent and having the power of attorney to legally bind the manufacturer.

SECTION XV- BANK GUARANTEE FORM FOR PERFORMANCE SECURITY

..... (Insert: Bank's Name, and Address of Issuing Branch or Office)

Beneficiary:

Bank Note Paper Mill India Private Limited
Administrative Building, Entry Gate 1,
Paper Mill Compound, Note Mudran Nagar,
Mysuru - 570003
Date:

Performance Guarantee No.:

WHEREAS.....(name and address of the supplier) (hereinafter called "the supplier") has undertaken, in pursuance of LOI (Letter of Intent) no..... dated to supply (description of goods and services) (herein after called "the contract").

AND WHEREAS it has been stipulated by you in the said LOI that the supplier shall furnish you with a bank guarantee by a scheduled commercial bank recognized by you for the sum specified therein as security for compliance with its obligations in accordance with the LOI;

AND WHEREAS we have agreed to give the supplier such a bank guarantee;

NOW THEREFORE we hereby affirm that we are guarantors and responsible to you, on behalf of the supplier, up to a total of..... (amount of the guarantee in words and figures), and we undertake to pay you, upon your first written demand declaring the supplier to be in default under the contract and without cavil or argument, any sum or sums within the limits of (amount of guarantee) as aforesaid, without your needing to prove or to show grounds or reasons for your demand or the sum specified therein.

We hereby waive the necessity of your demanding the said debt from the supplier before presenting us with the demand. We further agree that no change or addition to or other modification of the terms of the contract to be performed thereunder or of any of the contract documents which may be made between you and the supplier shall in any way release us from any liability under this guarantee and we hereby waive notice of any such change, addition or modification.

We undertake to pay Bank Note Paper Mill India Private Limited up to the above amount upon receipt of its first written demand, without Bank Note Paper Mill India Private Limited having to substantiate its demand.

This guarantee will remain in force for a period of sixty days after the currency of this contract and any demand in respect thereof should reach the Bank not later than the above date.

(Signature of the authorized officer of the Bank)

Name, Authorization/ Signature no. and Designation of the officer

Seal, Name & Address of the Bank and Address of the Branch

SECTION XV- BANK GUARANTEE FORM FOR PERFORMANCE SECURITY

Checklist for Bank Guarantee:

Performance BG should be in line with / comply the following.

1. BG should be issued on not less than Rs. 200/- e- stamp / non judicial stamp paper only.
2. Non judicial stamp paper / e-stamp paper should be purchased in the name of BG issuing bank only.
3. In case of stamp/e-stamp paper first party should be BG issuing bank and second party should be BNPM.
4. Date of sale of non-judicial / e-stamp paper shown on the BG and the stamp paper (BG) issued should not more than six months prior to the date of execution of BG.
5. Executing officer of BG should indicate his name, designation and power of attorney number / signing power no etc. on each page of BG.
6. Name and address of the bidding party, name and address of BNPM and value are to be mentioned clearly.
7. Overwriting / cutting if any in BG should be authenticated under signature and seal of authorized signatory of BG issuing Bank.
8. BG number and BG date should be mentioned in all pages of BG and all pages are endorsed / signed by authorized signatories of issuing bank.
9. Amount mentioned in figures and words are to be matched.
10. Validity of BG should be in line with the contract.
11. BG should be unconditional.
12. Our Bank details is mentioned below:

Name of the Bank: HDFC Bank.

Name of the Branch: Richmond Road Branch.

Branch Address: No. 8/24, Salco Centre, Bangalore- 560025, Karnataka.

IFSC: HDFC0000523.

SECTION XVI- CONTRACT FORM

**NOT APPLICABLE TO THIS
TENDER DOCUMENT**

**SECTION XVII- LETTER OF AUTHORITY FOR ATTENDING BID
OPENING**

**NOT APPLICABLE TO THIS
TENDER DOCUMENT**

SECTION XVIII- SHIPPING ARRANGEMENTS FOR LINER CARGOES

**NOT APPLICABLE TO THIS
TENDER DOCUMENT**

SECTION XIX- PROFORMA OF BILLS FOR PAYMENT

**NOT APPLICABLE TO THIS
TENDER DOCUMENT**



**SECTION XX- PROFORMA FOR PRE-CONTRACT INTEGRITY
PACT**

**NOT APPLICABLE TO THIS
TENDER DOCUMENT**